

MPT-8C

Standard Solid State

PULSE TOTALIZING RELAY INSTRUCTION SHEET

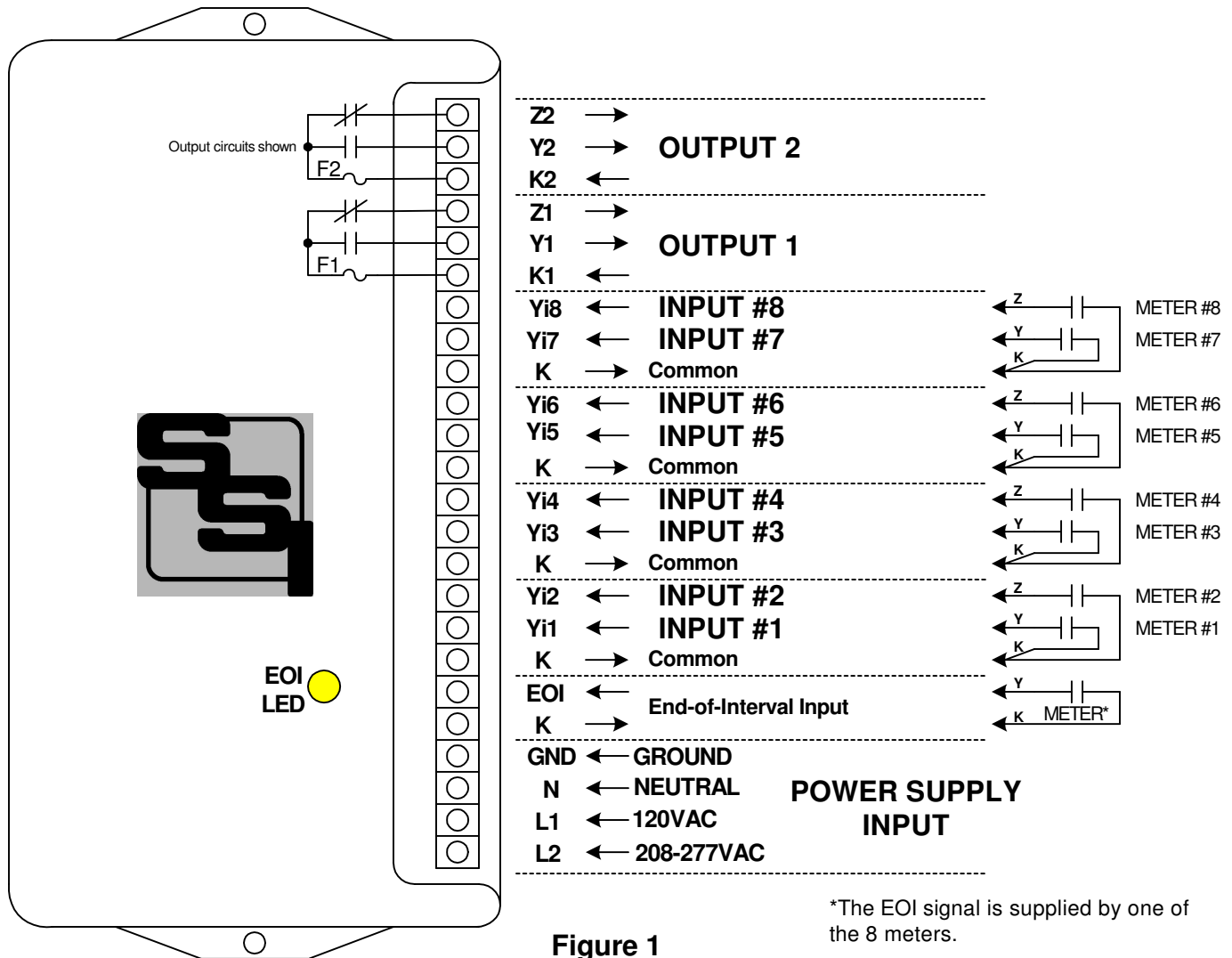
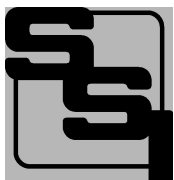

Figure 1

*The EOI signal is supplied by one of the 8 meters.

POWER INPUT - To power the MPT-8C with a 120VAC power supply, connect the "hot" 120VAC lead to the **L1** terminals. Connect the neutral lead to the **N** terminal. For 208, 240 or 277 VAC operation, connect the "hot" lead to the **L2** terminal. Connect the **GND** terminal to the electrical system ground. If a true Neutral does not exist at the mounting location, connect both **N** and **GND** to ground.

METER CONNECTIONS - The MPT-8C accepts 2-Wire inputs only. The MPT-8C's K terminals provide the common return for all of the meters' K terminals. One K terminal is provided for each set of two Yi pulse inputs. Connect each meter's Y output to the desired Yi input terminal. Each Yi input provides its own wetting (sense) voltage to the meter's Y terminal. The meters' pulse outputs can be dry-contact, solid state or electro-mechanical.



SOLID STATE INSTRUMENTS

a division of Brayden Automation Corp.
6230 Aviation Circle, Loveland Colorado 80538
Phone: (970)461-9600 Fax: (970)461-9605
E-mail: support@solidstateinstruments.com

OUTPUTS - Two 3-Wire isolated outputs are provided on the MPT-8C. MOV Transient suppression for the contacts of the solid-state relays is provided internally. The output loads should be limited to 1/10 Amp by F1 & F2. Two 1/10 Amp fuses are supplied standard with the unit unless otherwise specified. The fuse is a 3AG (AGC) fast blow type.

OUTPUT CONFIGURATION - Each output channel of the MPT-8C may be configured as one Form C (3-Wire) output or two independent Form A (2-Wire) outputs. The output configuration is configured in the OUT MODE display. If the Form C output mode is selected, Outputs 1 and 2 operate in tandem, that is, both operate in Form C mode and use a "toggle" pulse operation. In this mode, K1-Y1 and K2-Y2, for example, are both closed at the same time and K1-Z1 and K2-Z2 are open.

USING THE OUTPUT IN 3-WIRE MODE - When the MPT-8C is operated in the Form C (3-Wire) mode, each output channel "toggles" to the opposite state --back and forth like a single-pole, double throw switch -- upon each pulse being outputted. For one pulse there is continuity between K and Y (a closure) while there is no continuity between K and Z (an open). Upon the next pulse being received from the meter they reverse positions, K-Z closes and K-Y opens. In Form C mode, Y and Z are always opposite of each other. When one is closed and the other is open. There is logic in the MPT-8C's software that disallows two FORM C pulses of the same type in a row. They MUST alternate KY, KZ, KY etc.

Each KYZ output is an isolated dry contact, meaning there is no voltage applied to it internally. The wetting voltage for each KYZ output of the MPT-8C output must be supplied by the receiving ("downstream") device or by an auxiliary power supply. The outputs are solid state and are non-polarized. They may be used for AC or DC voltages. The output is limited to 100mA@ 250VAC, 800mW maximum. Fuses are sized at 1/10th amp (100mA). Do not exceed this rating as the solid state MOS-FET switching device may be destroyed. Internal current limiting of the solid state devices is also employed to protect them from over current or high dissipation situations. In the Form C mode, it is perfectly acceptable to use only two wires on the MPT-8C's output to the downstream device. Remember to double the Form C pulse constant if your receiving device does not automatically adjust the pulse value. Most energy management systems actually prefer a "toggle" pulse because it is generally a 50/50 duty cycle.

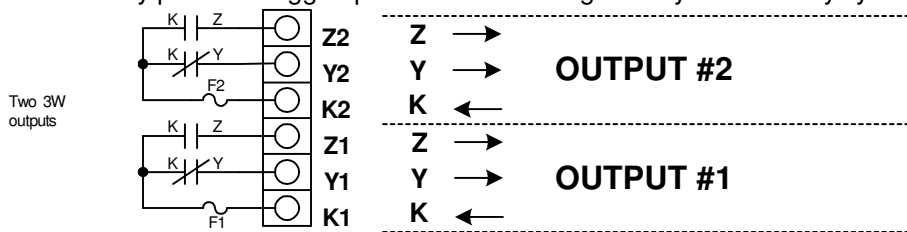
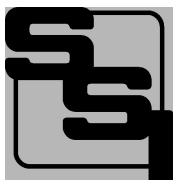

Figure 2

USING THE OUTPUT IN 2-WIRE MODE -

The MPT-8C's two KYZ outputs contain four solid state Form A dry-contacts and may be used independently as four Form A outputs in two KY and KZ pairs. In this case instead of Y and Z of each output being opposite of each other, they are independently used. (See Figure 3). These outputs operate in the momentary mode, meaning they close for a fixed period of time then reset to an open state. Even though the devices are operated independently in Form A mode, each set (Y1A-Z1A and Y2A-Z2B) must be operated at the same voltage, from the same voltage source since they have a shared common.

When the Output Mode display is set to "A", the two output channels each have a unique Output Pulse Value that can be individually set so different pulse output values are possible. To use the two output mode a clear understanding is necessary by the installer or user. There is a difference between the Hardware Outputs and the Software Channels. Output #1 (Hardware) consists of a 3-Wire pulse output consisting of K1, Y1 and Z1 output terminals. (Continued on next page)



SOLID STATE INSTRUMENTS

a division of Brayden Automation Corp.
6230 Aviation Circle, Loveland Colorado 80538
Phone: (970)461-9600 Fax: (970)461-9605
E-mail: support@solidstateinstruments.com

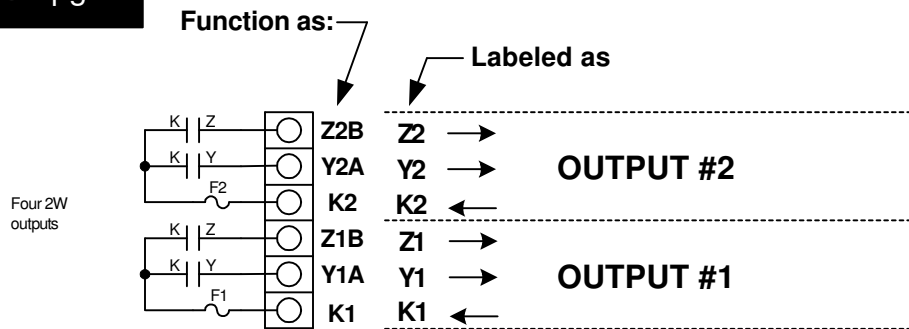

Figure 3

(Continued from Page 2:)

Output #2 (Hardware) consists of a second 3-Wire pulse output consisting of K2, Y2 and Z2 output terminals (See Figure 3 on Page 3.) In the Form A (2-Wire) output mode, the MPT-8C has two software output "Channels" that operate the hardware outputs individually. Channel 1, denoted by the suffix "A" operates the two outputs designated as Y1A and Y2A. Channel B is denoted by the suffix "B" and operates the two outputs designated as Z1B and Z2B. Each software output operates its two hardware outputs in tandem, meaning that both hardware outputs close and open together. For example, whenever a pulse is outputted on Software output Channel #1, both Y1A and Y2A close (connect to) to their respective K terminals. In other words, upon a closure of this channel, K1 and Y1A have continuity; K2 and Y2A have continuity. Likewise, when a pulse is outputted on Software output Channel #2, K1 and Z1B have continuity; K2 and Z2B will have continuity.

Note: YxB and ZxA do not exist in this numbering scheme. The second digit (numerical) denotes the Hardware output, either 1 or 2. The third digit (alpha) denotes the software channel, either A or B.

In the Form A output mode, there are several other differences.

Output Pulse Width Setting: The outputs' dwell or closure time is controlled by the AOUT1_TMS and AOUT2_TMS settings. See the MPT-8C programming manual for more information on this setting. These settings range from 100mS to 1000mS in 100mS increments. It is important to know the minimum pulse width specification of the receiving equipment. The output pulse width time must be set so that pulses will be reliably "seen" by the pulse receiving equipment. If pulses are too short, they will either not be counted at all or may be intermittently received. Most equipment will see pulses down to 50 mS, so 100 mS is a good default value. This value should be kept as short as possible (so as not to skew demand information in the event that pulses are outputted rapidly) but long enough to be reliable.

End-of-Interval (EOI) pulse Input: If the demand function of the MPT-8C is used, an end-of-interval signal must be provided by one of the meters supplying energy pulses to the MPT-8C. A Form A (2-Wire) dry-contact relay output can be directly connected to the EOI and K terminals. The MPT-8C provides its own +13VDC wetting voltage to this dry-contact so no other voltage source is needed.

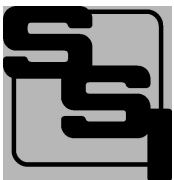

SOLID STATE INSTRUMENTS

a division of Brayden Automation Corp.
 6230 Aviation Circle, Loveland Colorado 80538
 Phone: (970)461-9600 Fax: (970)461-9605
 E-mail: support@solidstateinstruments.com

MPT-8C Electrical Wiring

Solid State Instruments, a Division of Brayden Automation Corp., Loveland, Colorado 80538 (970)461-9600

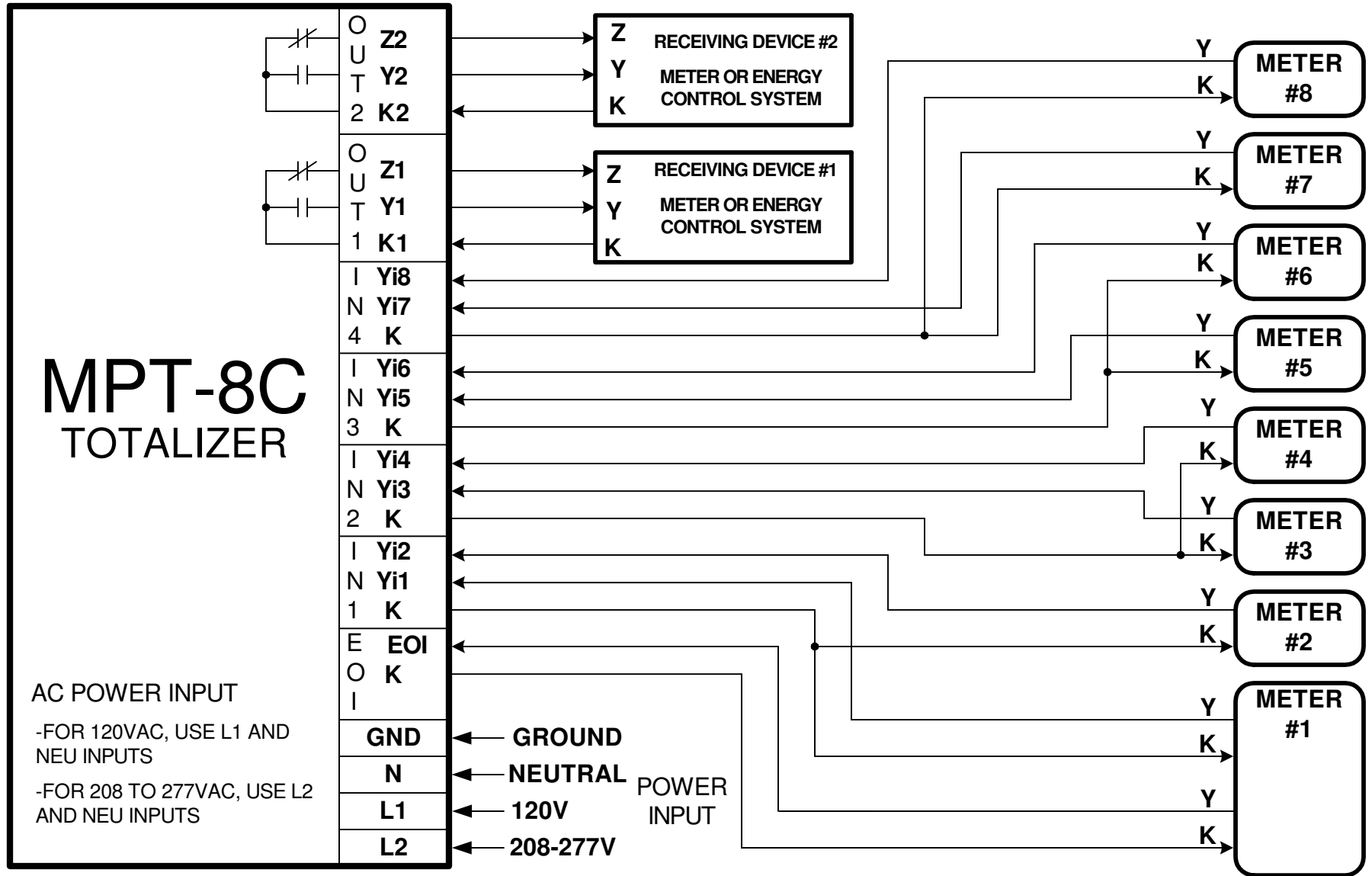

NOTE: A Sense Voltage of +13VDC is applied to the meters via the "Y" leads from the MPT-8C. The "K" lead is the common return.

PROGRAMMING THE MPT-8C TOTALIZER

Version 3.0 Software

The MPT-8C Pulse Totalizer is programmed by using the three small pushbutton switches (keys) located just above the LCD display. The left key with the yellow cap is the "Back" or Previous screen key. The middle key with the orange cap is the "Forward" key or Next key and moves the cursor (the dash under a number on the LCD display) forward from display item to item. The right pushbutton switch (key) with the black cap is Change Setting key and is used to change the value in the column above the cursor. If the value above the cursor were 5, pressing the black key three times would change the display above the cursor to 8. Continued pressing of the black key would advance the number to the value 9 and then 0, then 1...2...3...4...5...6...7...8...9...0...and so on. When the desired value is reached, press the orange key to move to the next display item. If the value at the present display position has been changed, the new value will be saved into memory as soon as you move the cursor to the next position. If no change is desired, just press the orange key again. Pressing the yellow key will move you to the previous screen. All functions of the totalizer are accessible by repeatedly pressing the yellow or orange key. Upon reaching the last screen, and pressing the orange key again, the display will loop back and start again at the first display. Consequently, all the inputs can be changed and saved with a combination of pushes of the yellow, orange and black keys, as the instructions that follow will illustrate.

START-UP DISPLAY: DISPLAYS SOFTWARE VERSION

When the MPT-8C is powered up, the start-up screen will be displayed. This screen displays the Model Number on the top line and software version number of the totalizer on the bottom line. **THE DISPLAY WILL AUTOMATICALLY GO TO THE FIRST DISPLAY SCREEN AFTER 5 SECONDS.**



START-UP DISPLAY

FIRST DISPLAY: STATUS OF INPUTS/OUTPUT

The Status display shows the current state of all inputs and outputs. Upon a closure (input pulse) of the "Y2" input, meter #2's status shown here on the display will change to a "Y". The current status of each input of the MPT-8C is displayed. Any input which is not used or open will have a "-" displayed in its position.

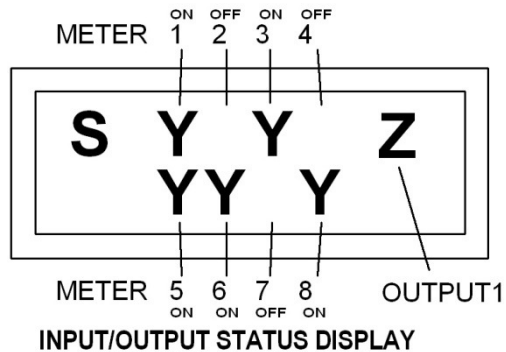

INPUT/OUTPUT STATUS DISPLAY

In Form C output mode, a one-digit output character will be displayed (as shown above), and either a Y or a Z will visible at all times. The “Z” displayed as an output status shows that the contacts between “K” and “Z” on the output are closed or “made up”. The “K” to “Y” output contacts are open. When the next pulse is outputted, the output character will change to “Y”. Upon power-up of the MPT-8C, both outputs are set in the K-Y position. Therefore, the next valid pulse outputted will be a K-Z closure.

In Form A mode, two output characters will be displayed. A “Y” will be displayed upon a pulse output for the time duration specified in the AOUT TMS settings. When the outputs are open (no pulse output occurring) the display will show a “-“. Upon power-up, the outputs are set in the open position and a “-“ will be shown in both output character positions. **PRESS THE ORANGE KEY TO GO TO NEXT DISPLAY.**

PULSE INPUTS

The MPT-8C has eight pulse inputs and each input screen consists of three pieces of information that must be programmed. These are the pulse sign, the pulse value and pulse input type. The pulse sign determines if the pulse is positive or negative. The pulse value the numerical value that represents what a pulse is worth. The pulse type is Form A (2-Wire) only on the MPT-8C. Only the K and Y inputs are used.

The Pulse Sign is used for adding or subtracting the pulse value from the pulse value (“PV”) register. It can be used to “net out” energy used where some values are positive and negative, like energy delivered and received, for example. If all inputs are positive then the totalizer will simply add all input pulse values. At least one input must always be a positive sign. Four negative inputs are not allowed for obvious reasons.

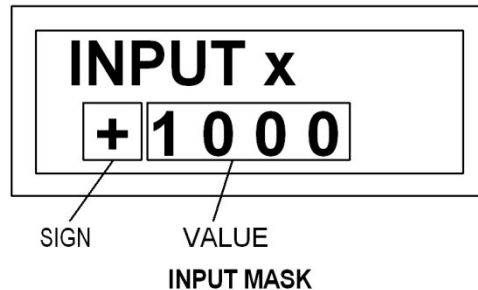

The Pulse Value is the actual numerical value that a pulse is worth, or the “pulse weight”. This can be expressed in kilowatt-hours, watt-hours, or var-hours or any other appropriate unit of measure. All inputs must have the same units.

SECOND DISPLAY:

METER #1 INPUT VALUES

The second display is the pulse sign, value and type programmed in for METER #1. The value or setting of each digit may be changed by first moving the cursor to the digit desired using the **ORANGE KEY**. To change the digit's value, press the **BLACK KEY**. Press this key any number of times until the desired number is displayed. Press the **ORANGE KEY** once to advance the cursor to the next position to the right. Again enter the correct number with the **BLACK KEY**. Press the **ORANGE KEY** once. Enter the third number with the **BLACK KEY**. Press the **ORANGE KEY** once and enter the fourth number with the **BLACK KEY**. Press the **ORANGE KEY** once and enter the type with the **BLACK KEY**. This time when you press the **ORANGE KEY**, you will advance to the third display.

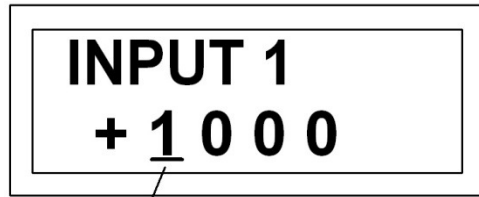

CURSOR
METER #1 KWH/P VALUE DISPLAY

THIRD DISPLAY:

METER #2 INPUT VALUES

The third display works to input values for METER #2 in the same manner as display #2 worked for METER #1.

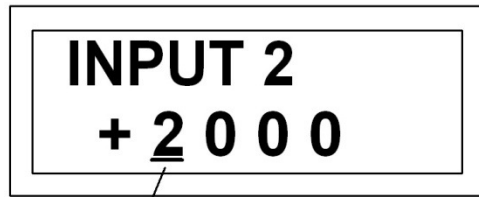

CURSOR
METER #2 KWH/P VALUE DISPLAY

FOURTH DISPLAY:

METER #3 INPUT VALUES

The fourth display works to input values for METER #3 in the same manner as display #2 worked for METER #1.

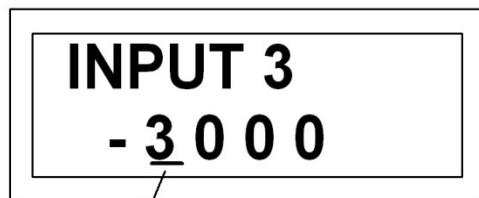

CURSOR
METER #3 KWH/P VALUE DISPLAY

FIFTH DISPLAY:

METER #4 INPUT VALUES

The fifth display works to input values for METER #4 in the same manner as display #2 worked for METER #1.

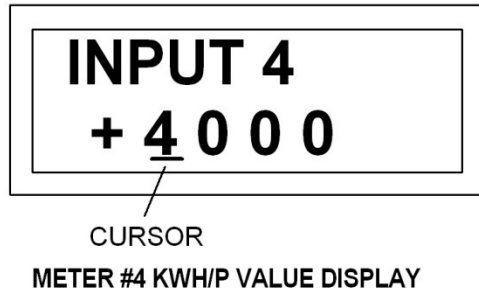

SIXTH DISPLAY:

METER #5 INPUT VALUES

The sixth display works to input values for METER #5 in the same manner as display #2 worked for METER #1.

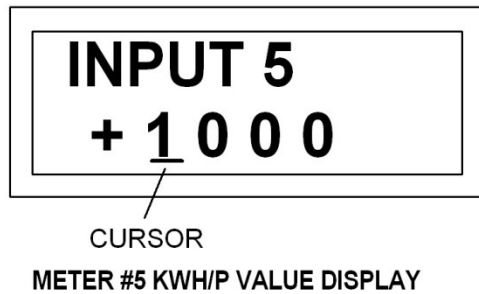

SEVENTH DISPLAY:

METER #6 INPUT VALUES

The seventh display works to input values for METER #6 in the same manner as display #2 worked for METER #1.

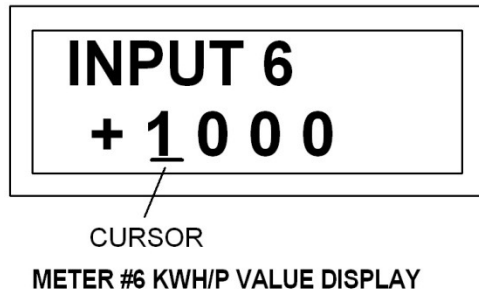

EIGHTH DISPLAY:

METER #7 INPUT VALUES

The eighth display works to input values for METER #7 in the same manner as display #2 worked for METER #1.

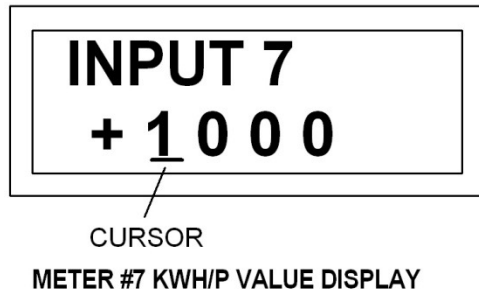

NINTH DISPLAY:

METER #8 INPUT VALUES

The ninth display works to input values for METER #8 in the same manner as display #2 worked for METER #1.

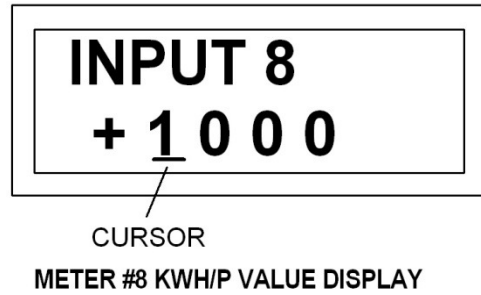

TENTH DISPLAY:

TOTALIZER OUTPUT MODE

The fourth display shows the output mode selection screen. You can select either one Form C (3-Wire) output or two Form A (2-Wire) outputs. Form C is a “toggle” output since it each outputted pulse toggles back and forth from K-Y to K-Z continuity or from K-Z to K-Y continuity, like a single pole, double throw (SPDT) switch. Form A is a momentary type of switch closure and is closed for the input pulse duration specified in the display called “AOUT1_mS”. Press the **BLACK** key to toggle back and forth between the Form A or Form C selection. Press the **ORANGE** key to move to the next display.

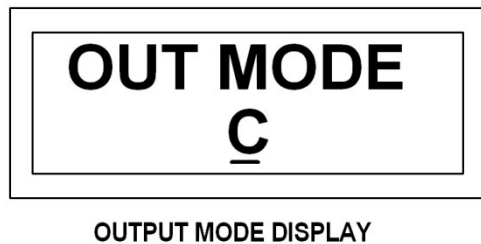

ELEVENTH DISPLAY:

TOTALIZER OUTPUT KWH/PULSE VALUE

If you selected the Form C output mode in the sixth display, you will land here. The output value setting, unlike the preceding meter input value displays, has 6 digits that may be set. The value of the Form C output is set in the same manner as the meter input displays. When the PV Total equals or exceeds the set value, the output pulse value is subtracted from the PV Total, and causes an output pulse (a change of state of the output relay) to occur. This value must be greater than or equal to 1 (one). If the user inadvertently puts zero (0) in this field, a one (1) will be automatically placed on the LCD in the furthest right position. The desired output value may then be entered. (See the note at the end of the manual on setting this value.)

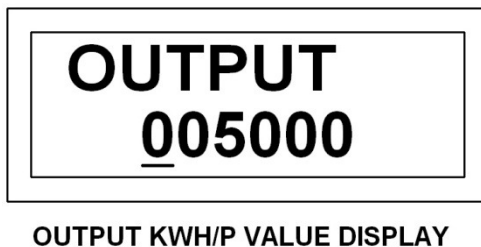

TWELVETH DISPLAY: TOTALIZER OUTPUT#1 KWH/PULSE
VALUE

If you selected Form A in the fourth display, you will arrive here. The eighth display, unlike the input meter value displays, has 6 digits that may be set. The value (or weight) of Output #1 is set in the same manner as the meter input displays by moving the cursor across the display using the Orange button. When the Pulse Value Total register equals or exceeds the set value, the output pulse value is subtracted from the PV Total, and causes an output pulse to occur. The outputted pulse has a closure of a time specified by the output time display AOUT1_mS. This value must be greater than or equal to 1 (one). If the user inadvertently puts zero (0) in this field such that all six digits are zeros, a one (1) will be automatically placed on the LCD in the furthest right position. The desired output value may then be entered.

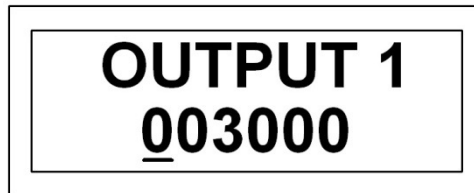

OUTPUT KWH/P VALUE DISPLAY

THIRTEENTH DISPLAY: TOTALIZER OUTPUT#2 KWH/PULSE
VALUE

The ninth display, like the eighth display, has 6 digits that may be set. The value (or weight) of Output #2 is set in the same manner as the meter input displays. When the Pulse Value Total register equals or exceeds this value, the output pulse value is subtracted from the PV Total, and causes an output pulse (a change of state of the output relay) to occur. The outputted pulse has a closure of a time specified by the output time display AOUT2_mS. This value must be greater than or equal to 1 (one). If the user inadvertently puts zero (0) in this field such that all six digits are zeros, a one (1) will be automatically placed on the LCD in the furthest right position. The desired output value may then be entered.

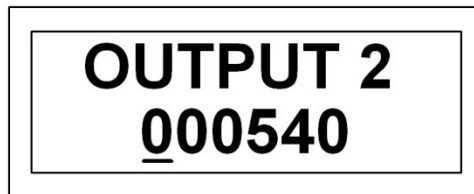

OUTPUT KWH/P VALUE DISPLAY

FOURTEENTH DISPLAY: PULSE OUTPUT #1 TIME

The tenth display allows you to set the time of a FORM A output on Output #1. The time may be set in 100-millisecond increments. The minimum time is 100 milliseconds. The maximum time is 1000 milliseconds (1 second). Thus only digits 1 and 2 of this display are programmable. The entry

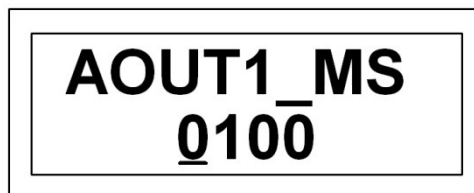

PULSE OUTPUT #1TIME DISPLAY

method is the same as that used to set the meter input values.

FIFTEENTH DISPLAY: PULSE OUTPUT #2 TIME

The fifteenth display allows you to set the time of a FORM A output on Output #2. The time may be set in 100-millisecond increments. The minimum time is 100 milliseconds. The maximum time is 1000 milliseconds (1 second). Thus only digits 1 and 2 of this display are programmable. The entry method is the same as that used to set the meter input values.

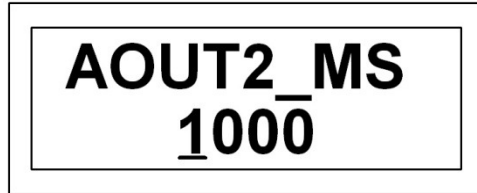

PULSE OUTPUT #2TIME DISPLAY

WARNING: Care should be taken not to make FORM A output pulses any longer than necessary since it may cause problems in periods of high demand if pulse values are too small.

SIXTEENTH DISPLAY: TIME BETWEEN OUTPUT PULSES

The sixteenth display allows you to set a minimum time between output pulses to accommodate differences in required recording equipment and relay minimal make-up times. The time is set in 10-millisecond increments. The minimum time is 20 milliseconds. The maximum time is 1000 milliseconds (1 second). The entry method is the same as that used to set the meter input values. This value also, should be kept as short as possible, but long enough to insure that the receiving equipment will “see” each pulse.



TIME BETWEEN PULSES DISPLAY

**SEVENTEENTH DISPLAY: PULSE VALUE REGISTER
CONFIGURATION**

If inputs #1-4 are all positive (+), this display automatically is skipped and the display skips to the eighteenth display. This display allows you to configure the PULSE VALUE TOTAL register to allow both a positive or negative balance, OR a positive balance only. The default setting is “Y” (for “yes”) - to allow the register balance to go negative. Press the **ORANGE** key to move to the next setting.



**ALLOW NEGATIVE
ACCUMULATOR DISPLAY**

If you desire to set the MPT-8C so that the pulse value register will be positive (or zero) ONLY, press the **BLACK** key to change the “Y” to an “N”. If you select the “N” (or “no”) value to this setting, the register will count down to zero but will not go negative. It will remain at zero until such time that enough positive pulses occur to make the pulse value register increment upwards. Press the **ORANGE** key to move to the next setting. If the MPT-8C has been running and has accumulated a negative value in the PV TOTAL register, AND the user changes the ALLW NEG value from “Y” to “N”, the PV TOTAL value is reset to zero (0). Note: This display will not show up in the display sequence if all inputs are a positive value.

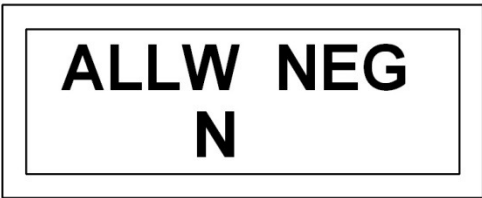

**DO NOT ALLOW NEGATIVE
ACCUMULATOR DISPLAY**

EIGHTEENTH DISPLAY: PULSE VALUE REGISTER DISPLAY

The eighteenth display shows the accumulated numerical energy value contained within the processor’s memory at any given time. For example, assume that you have set METER #1’s input pulse value to 2000, an OUTPUT pulse value of 005000 and a TIME BETWEEN PULSES value of 500 mS. Upon entering three (3) pulses into METER #1’s inputs, several things happen. First, the pulse accumulator registers a value of 6000 (3 pulses X 2000/pulse). Since the accumulator is greater than the Output Pulse Value setting (5000), an output pulse occurs. Next, 5000 (the output value) is subtracted, leaving a remaining balance of 1000 in the PV TOTAL register. Finally, if the total in the PV had still exceeded 5000, then after 500mS, another output pulse would have occurred. The remainder will usually be smaller than the output pulse value and is only awaiting sufficient pulses at the meter inputs before a new output pulse is generated and a new smaller remainder calculated. This setting is stored in non-volatile memory upon loss of power.



PULSE VALUE DISPLAY

**NINETEENTH DISPLAY: PULSE VALUE DISPLAY
FORM A OUTPUT MODE, OUTPUT #1**

The nineteenth display shows Output #1’s accumulated numerical pulse value contained within the processor’s memory at any given time. For example, assume that you have set METER #1’s input pulse value to 2000, an OUTPUT pulse value of 005000



PULSE VALUE DISPLAY

and a TIME BETWEEN PULSES value of 500 mS. Upon receiving three (3) pulses at METER #1's input, several things happen. First, the pulse accumulator registers a value of 6000 (3 pulses X 2000/pulse). Since the accumulator is greater than the Output Pulse Value setting (5000), an output pulse occurs. Next, 5000 (the output value) is subtracted, leaving a display of 1000 in the PV1TOTAL display. Finally, if the total in the PV had still exceeded 5000, then after 500mS, another output pulse would have occurred. The remainder will usually be smaller than the output pulse value and is only awaiting sufficient pulses at the meter inputs before a new output pulse is generated and a new smaller remainder calculated. This setting is stored in non-volatile memory upon loss of power.

TWENTIETH DISPLAY: PULSE VALUE DISPLAY
FORM A OUTPUT MODE, OUTPUT #2

The twentieth display shows Output #2's accumulated numerical pulse value contained within the processor's memory at any given time. This setting is stored in non-volatile memory upon loss of power.



PULSE VALUE DISPLAY

TWENTY-FIRST DISPLAY: INPUT PULSE COUNT – METER #1

The twenty-first display allows you to see the total number of pulses that have been counted by meter input #1 since the last reset. This number is simply a counter that increments by one (1) count each time a pulse is recorded by meter input #1. This value is non-weighted and represents the number of counts only. This count is saved in non-volatile memory upon loss of power. Nothing on this display can be changed. It is for informational only. Press the **ORANGE KEY** to advance to the next display.



METER #1 PULSE COUNT DISPLAY

22ND THROUGH 28TH DISPLAYS: INPUT PULSE COUNT–METERS #2-8

The next 7 displays show the total number of pulses for each meter for meters #2 thru 8. Each display shows the raw pulse count since last reset. This counter increments by one (1) count each time a pulse is recorded



METER #8 PULSE COUNT DISPLAY

by meter each meter input. This value is non-weighted and represents the number of counts only. This count is saved in non-volatile memory upon loss of power. Press the **ORANGE KEY** to advance to the next display.

TWENTY-NINTH DISPLAY: **OUTPUT PULSE COUNT**

The twenty-ninth display allows you to see the total number of FORM C output pulses that have been outputted since the last reset. This number is a counter that increments by one (1) count each time a pulse is sent to the output relay. This value is non-weighted and represents the number of counts only. This count is saved in non-volatile memory upon loss of power. Press the **ORANGE KEY** to advance to the next display.

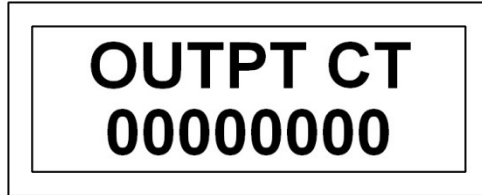

OUTPUT PULSE COUNT DISPLAY

THIRTIETH DISPLAY: **OUTPUT PULSE COUNT-OUTPUT #1**

If you selected the A output mode in the tenth display, the thirtieth display allows you to see the total number of FORM A output pulses on Output #1 that have been outputted since the last reset. This number represents a pulse counter that increments by one (1) count each time a pulse is sent to the output relay #1. This value is non-weighted and represents the raw number of output #1's counts only. This count is saved in non-volatile memory upon loss of power. Press the **ORANGE KEY** to advance to the next display.



OUTPUT 1 PULSE COUNT DISPLAY

THIRTY-FIRST DISPLAY: **OUTPUT PULSE COUNT-OUTPUT #2**

If you selected the A output mode in the tenth display, the thirty-first display allows you to see the total number of FORM A output pulses on Output #2 that have been outputted since the last reset. This number represents a pulse counter that increments by one (1) count each time a pulse is sent to the output relay #2. This value is non-weighted and represents the raw number of output #2's counts only. This count is saved in non-volatile memory upon loss of power. Press the **ORANGE KEY** to advance to the next display.



OUTPUT 2 PULSE COUNT DISPLAY

Capturing Totalized Peak Demand

In some totalizing applications it may be desirable to capture the peak demand of all of the meters being totalized. The MPT-8C has the capability to do this. Peak demand is measured in kW and represents the one interval that has the highest kWh usage in it, since the last demand reset. For the peak demand feature of the MPT-8C to work correctly, the Pulse Input values must be accurate and cannot be a ratio of their value.

THIRTY-SECOND DISPLAY: DEMAND ENABLE

To use the Peak Demand capability, an End-of-Interval signal is required from one of the four meters supplying pulses to the MPT-8C. A 2-wire Form A dry-contact switch is connected to the EOI input. To use the Demand capability, set the Demand Enable display to "ON". If demand will not be used, turn the Demand Enable screen to "OFF". If demand is disabled the next five displays will not appear in the display sequence.



DEMAND ENABLE DISPLAY

THIRTY-THIRD DISPLAY: DEMAND INTERVAL LENGTH

Enter the length of the demand interval. Although the start and stop of each interval is controlled by the EOI input, the MPT-8C must have the same interval time as the meter stored in it to correctly calculate the peak demand. The options are 1, 2, 5, 10, 15, 30, and 60 minutes. The default setting is 15 minutes.



DEMAND INTERVAL LENGTH DISPLAY

THIRTY-FOURTH DISPLAY: INTERVAL KWH

This display shows the number of kilowatt-hours (kWh) received by the totalizer in the current interval from the positive (+) and negative inputs. If all inputs are positive then this is simply the accumulated total energy value during the interval. If any of the meters have a negative pulse value, then the kWh value in the INT kWh register will be the "net" positive energy value. If, of course, more negative energy value than positive energy value has been received at the end of the interval, the demand will be zero.



DEMAND INTERVAL ENERGY DISPLAY

THIRTY-FIFTH DISPLAY: LAST INTERVAL'S DEMAND - KW

This display shows the peak kW demand for the last interval for which an end of interval (EOI) pulse was received. This is the number of kWh received during the previous interval, divided by the interval's length in hours. For example, if 12 kWh were accumulated in a 15 minute (.25 hours) interval, the demand for that interval would be $12 / .25 = 48\text{kW}$.



LAST INTERVAL DEMAND DISPLAY

THIRTY-SIXTH DISPLAY: TOTALIZED PEAK DEMAND - KW

This display shows the highest interval kW that has been measured since last reset of the Demand Register. Over a typical 30 day billing period, there are about 2900 15-minute intervals. This captures the highest interval's totalized peak demand.



TOTALIZED PEAK DEMAND DISPLAY

Since peak demand is measured on kWh delivered, only those input pulses with a positive value are used in the peak demand calculation.

THIRTY-SEVENTH THIRD DISPLAY: RESET PEAK DEMAND REGISTER

The thirty-seven display allows you to reset the peak demand registers since the last reset in the Peak kW Demand Register. The default of this display is "N" for no. To move forward and not reset the totals, press the ORANGE KEY.



RESET PEAK DEMAND DISPLAY

To reset the Peak Demand register to zero, press and hold down the **BLACK KEY** for 3



RESET PEAK DEMAND DISPLAY

seconds. A “Y” will be displayed, indicating that you are correctly pressing the key.

Once the MPT-8C has correctly reset all demand registers to zero, the display will indicate DONE! Let off the **BLACK KEY**. Upon releasing the **BLACK KEY**, the display will automatically move to the next display.



RESET PEAK DEMAND DISPLAY

THIRTY-EIGHTH DISPLAY: RESET COUNTERS

The thirty-eighth display allows you to reset the eight INPUT counters, the OUTPUT counter(s), and the PV TOTAL register(s), all at one time. The default of this display is “N” for no. To go back to the status display and not reset the totals, press the **ORANGE KEY**.



RESET COUNT DISPLAY

To reset all counters to zero, press and hold down the **BLACK KEY** for 3 seconds. A “Y” will be displayed, indicating that you are correctly pressing the key.



RESET COUNT DISPLAY

Once the MPT-8C has correctly reset all counters to zero, the display will indicate DONE. Let off the **BLACK KEY**. Upon releasing the **BLACK KEY**, the display will automatically jump back to the first display, the Status display.



RESET COUNT DISPLAY

INFORMATION ON SCALING OF VALUES FOR DATA ENTRY

The MPT-8C is a ratio device. The term “ratio device” means that if the number in the right most column of the value for meter #1 is the “ones” value for KWH/PULSE, then all other values in the far right-hand column will also

represent “ones”. The second column to the left of the right column will represent “tens” values. The third column will represent the “hundreds” values, etc. This means that the decimal point, when used, can be located between any two columns or to the left or right of the first or last digit. However, once the decimal point is decided and “mentally placed” in a column, it must run top to bottom in that position only for all input settings. **The decimal point does not actually appear on the display. You simply decide where the decimal point is going to be.**

EXAMPLES

CORRECT

METER #1 .1000
 METER #2 .1234
 METER #3 .2345
 METER #4 .3456
 OUTPUT 05.0000

CORRECT

METER #1 1.000
 METER #2 1.234
 METER #3 2.345
 METER #4 3.456
 OUTPUT 05.000

INCORRECT

METER #1 .1000
 METER #2 1.234
 METER #3 .2345
 METER #4 345.6
 OUTPUT 05.0000

INCORRECT

METER #1 1000.
 METER #2 123.4
 METER #3 23.45
 METER #4 3.456
 OUTPUT 00.5000

While we have used KWH/PULSE for the pulse values throughout this document, the values could be watts, megawatts, gallons or any other common unit of measure.

NOTE ON OUTPUT PULSE VALUES

In general, it is bad practice to make the output pulse value(s) smaller than the smallest input value. This is because you will often get two pulses out for each input pulse in, in rapid succession, in the worst case scenario. Too many pulses out with erratic timing will cause peak demand management systems to incorrectly register the instantaneous or current demand. It is recommended that the output pulse value(s) be larger or equal to the largest input pulse value.

TECHNICAL SUPPORT

For additional information or technical help, call Brayden Automation Corp./Solid State Instruments division at (970) 461-9600 or toll free at (888)BRAYDEN.

INSTALLATION RECORD

METER

NAME/NUMBER.....

METER LOCATION.....

DATE INSTALLED.....

TOTALIZER TYPE..... MPT-8C

SOFTWARE VERSION VERSION 3.0

MANUFACTURER..... SOLID STATE INSTRUMENTS

A division of Brayden Automation Corp.
6230 Aviation Circle
Loveland, CO 80538

TECH SUPPORT (970) 461-9600

FILL OUT BEFORE PROGRAMMING TOTALIZER

METER # 1 AREA OR NAME KWH/PULSE

METER # 2 AREA OR NAME KWH/PULSE

METER # 3 AREA OR NAME KWH/PULSE

METER # 4 AREA OR NAME KWH/PULSE

METER # 5 AREA OR NAME KWH/PULSE

METER # 6 AREA OR NAME KWH/PULSE

METER # 7 AREA OR NAME KWH/PULSE

METER # 8 AREA OR NAME KWH/PULSE

OUTPUT #1 VALUE KWH/PULSE

OUTPUT #2 VALUE KWH/PULSE

NOTE: The MPT-8C does not actually display a decimal point. Simply decide where you want the decimal point to be and enter all numbers accordingly. When entering your values on the above record/worksheet, all decimals for data entries **must** be in a vertical straight line for the math to work correctly. The decimal point may be between, before or after any column.