

DPR-4

Standard Solid State

HIGH SPEED DIVIDING PULSE RELAY INSTRUCTION SHEET

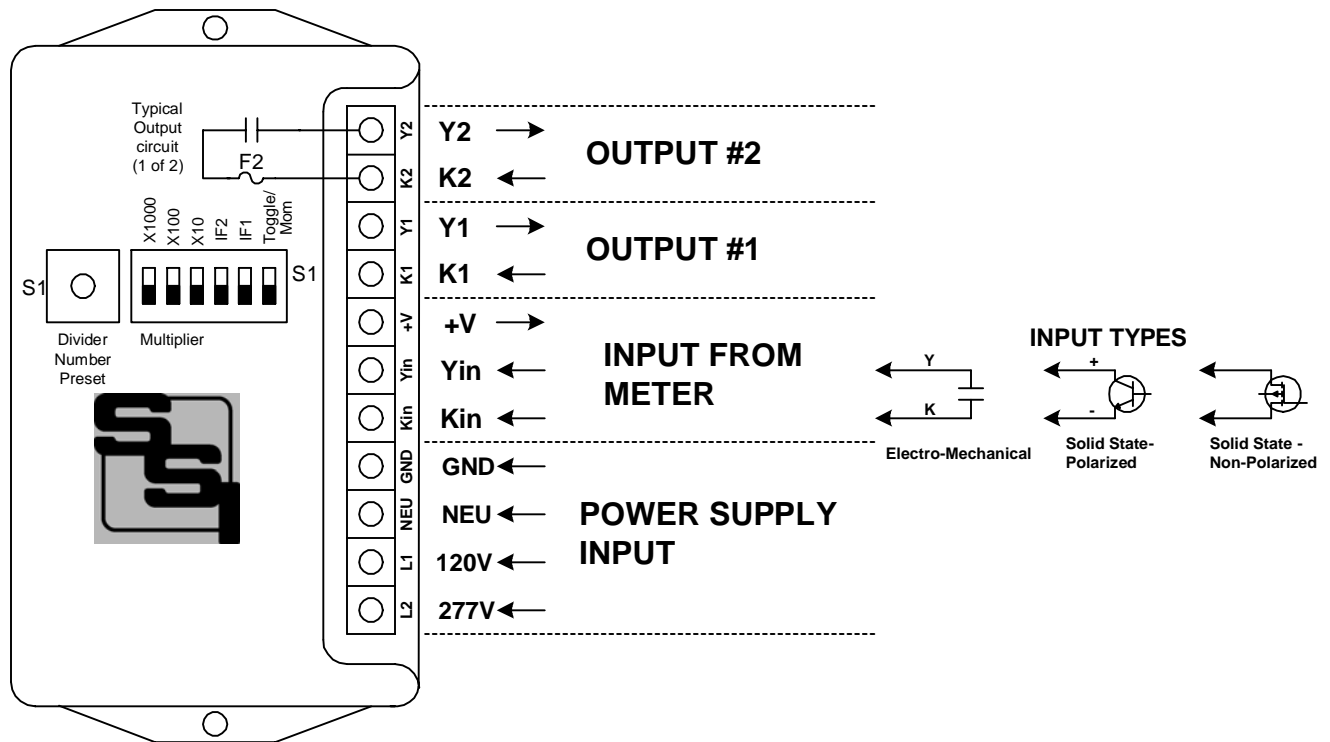

MOUNTING POSITION - The DPR-4 can be mounted in any position.

POWER INPUT - For a power supply voltage of 120 VAC, connect the hot lead (Black) to the **L1** terminal. For 208 to 277VAC, connect the hot lead to the **L2** terminal. Connect the neutral lead (White) to the **NEU** terminal. Connect the **GND** terminal to the electrical system ground. The G round lead must be connected and cannot be left floating (unconnected).

METER CONNECTIONS - The DPR-4 has a 2-wire (Form A) input. The DPR-4's **Kin** and **Yin** input terminals should be connected to the meter's "K" and "Y" terminals. The DPR-4's "Kin" is common & provides the return from the meter's K terminal. The "Yin" input provides a "pulled-up" +5VDC to the meter's "Y" terminal. When connecting to a gas or water meter with a polarized output, connect the positive (+) to the Yin terminal and the negative (-) to the Kin terminal. If the meter's transmitter must be powered, it can be powered by the auxiliary power supply terminal **+V** which can supply +12VDC at up to 40mA to the meter.

OUTPUT - Two 2-wire (Form A) isolated outputs with transient voltage suppression are provided. Outputs are rated up to 120VAC/125VDC at 100mA (1/10th Amp) with a maximum of 800mW.

FUSE - The fuses are 3AG or AGC type and may be up to 1/10th Amp in size.

DIVISION NUMBER and MULTIPLIER SWITCHES - The divider number and multiplier switches are located just above the microcontroller in the center of the board. See the table on Page 2 for dividing number switch settings from 1 to 10,000.



SOLID STATE INSTRUMENTS

a division of Brayden Automation Corp.
6230 Aviation Circle, Loveland Colorado 80538
Phone: (970)461-9600 Fax: (970)461-9605
Email: Support@brayden.com

CHOOSE THE DIVIDER #: The Divider # is the number of pulses IN for each pulse OUT. It is equal to the 1-10 Switch Preset Number times the Multiplier. Choose the desired DIVIDER # by determining a number from 1 to 10 and the multiplier, X1, X10, X100 or X1000. All possible divider combinations are shown in Table 1. Rotate the Switch (S1) to the desired number from 1 to 10 ("0" = 10). Set the multiplier jumper to one of the four possible configurations in Table 2 below. For example, to divide by 700, set Switch S1 at "7" and the Multiplier Jumper to "X100". When 700 pulses are received, the output will output either a toggle or momentary pulse, depending on the pulse output mode selected.

SET MAXIMUM INPUT FREQUENCY: The DPR-4 also features input debouncing. Table 3 below shows possible configurations. Set the next highest input frequency higher than the maximum input pulse frequency of your application. Use switches 4 and 5 of Switch S2.

SET OUTPUT MODE: For the TOGGLE output mode, set switch position #6 of S2 to the "DOWN" position. For the MOMENTARY mode, set switch #6 of S2 in the "UP" position. In the toggle mode the output will change to the opposite state when the divider number is reached. In the momentary mode, a 100mS output pulse will occur.

RESET COUNT: The DPR-4 saves the current pulse count in the event that power is lost to the unit. It may be desirable to reset this count, particularly during testing and/or if the divider number is large. To reset the count to zero, set both switches 4 and 5 up. Recycle power. Set switches 4 and 5 of S2 for desired setting.

LED INPUT & OUTPUT INDICATORS: The DPR-4 includes a high-brightness Red LED for the input and a Green LED for the output. The Red LED will light when the input is active. The Green LED will light when the output is "closed". The Yellow LED is a power supply indicator which lights whenever +5V is present.

TABLE 1

SWITCH PRESET NUMBER	MULTIPLIER			
	X1	X10	X100	X1000
1	1	10	100	1000
2	2	20	200	2000
3	3	30	300	3000
4	4	40	400	4000
5	5	50	500	5000
6	6	60	600	6000
7	7	70	700	7000
8	8	80	800	8000
9	9	90	900	9000
10	10	100	1000	10000

TABLE 2

SETTING THE MULTIPLIER

X	S2.1	S2.2	S2.3
1	0	0	0
10	0	0	1
100	0	1	0
1000	1	0	0

0 = Switch DOWN

1 = Switch UP

Only the highest multiplier is used if more than one multiplier switch is in the "UP" position.

SETTING THE MAX. INPUT FREQUENCY (IF1 and IF2)

TABLE 3

Hz	S2.4 (IF2)	S2.5 (IF1)
RST	1	1
100	1	0
1000	0	1
5000	0	0

SETTING THE OUTPUT MODE

TABLE 4

S2.6	MODE
0	Toggle
1	Momentary



SOLID STATE INSTRUMENTS

a division of Brayden Automation Corp.
 6230 Aviation Circle, Loveland, Colorado 80538
 Phone: (970)461-9600 Fax: (970)461-9605
 E-mail: support@solidstateinstruments.com

"We're all about K, Y and Z"

DPR-4 OUTPUT MODES

TOGGLE MODE: The DPR-4's output when in toggle mode, will change state to the opposite state when a pre-defined number of pulses is received. In Figure 1 below, a count is registered when the input closes and there is continuity between the Kin and Yin input terminals. The return to the original state (input open) does not count as a pulse. When the number of pulses received is equal to the count preset number (n), the output changes to the opposite state. This mode is used when both positive and negative output transitions are counted.

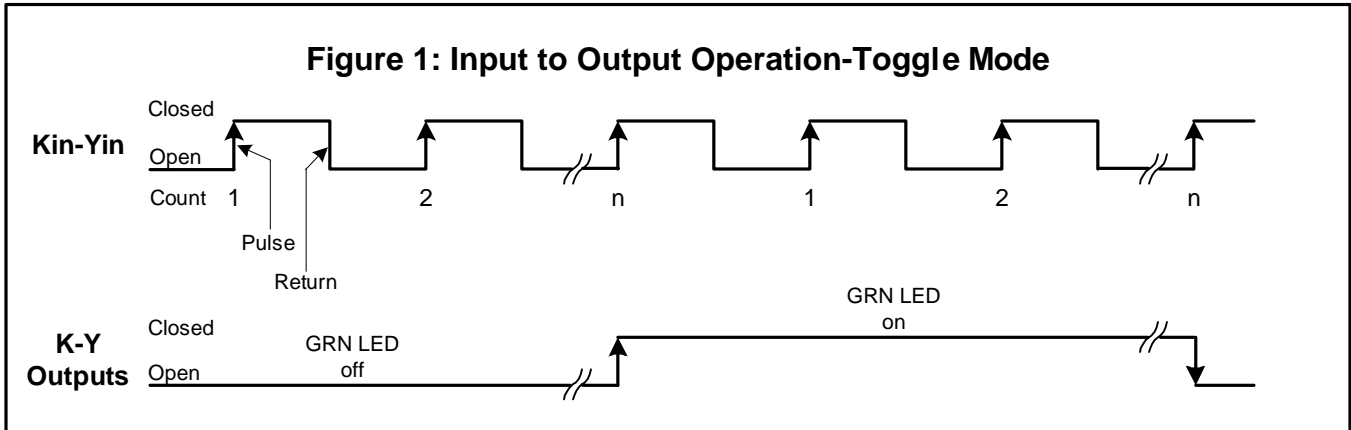

MOMENTARY MODE: When the DPR-4's output is set for momentary mode, a 100mS output pulse will occur when the pre-defined number of pulses is received. In Figure 2 below, a count is registered when the input closes and there is continuity between the Kin and Yin input terminals. The return to the original state (input open) does not count as a pulse. When the number of pulses received is equal to the count preset number (n), the output changes to the "closed" state for 100mS and then returns to the "open" state. This mode is used when only the closing of the output is counted.

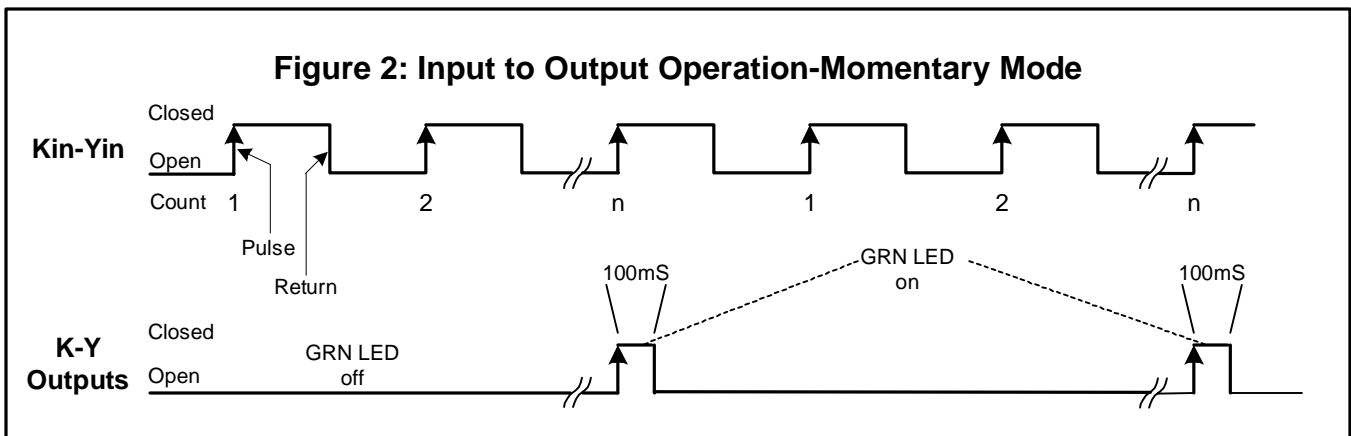

The DPR-4 can output a fixed maximum rate of 5 pulses per second of 100mS in duration, with 100mS spaces between the pulses. In the event that the frequency of incoming pulses is high and the divider number is low, such that the output frequency exceeds 5 pulses per second, the DPR-4 will store up to 255 pulses and output them when possible. If this problem persists, a higher divider number is recommended which will result in fewer pulses of greater value.

POWERING A WATER METER TRANSMITTER

+V OUTPUT: Some water meters require a power source to run the electronics ("transmitter") required to give a pulse output. In the event that you have a water meter with this requirement, the DPR-4 includes a power supply output terminal for this purpose. This terminal is marked "+V" and is the 7th terminal up from the bottom. The voltage of this output pin varies with load between +12 and +18VDC. Current available on this pin to power the water meter transmitter is limited to 40mA. The drawing below shows the connection of the water meter to the DPR-4.

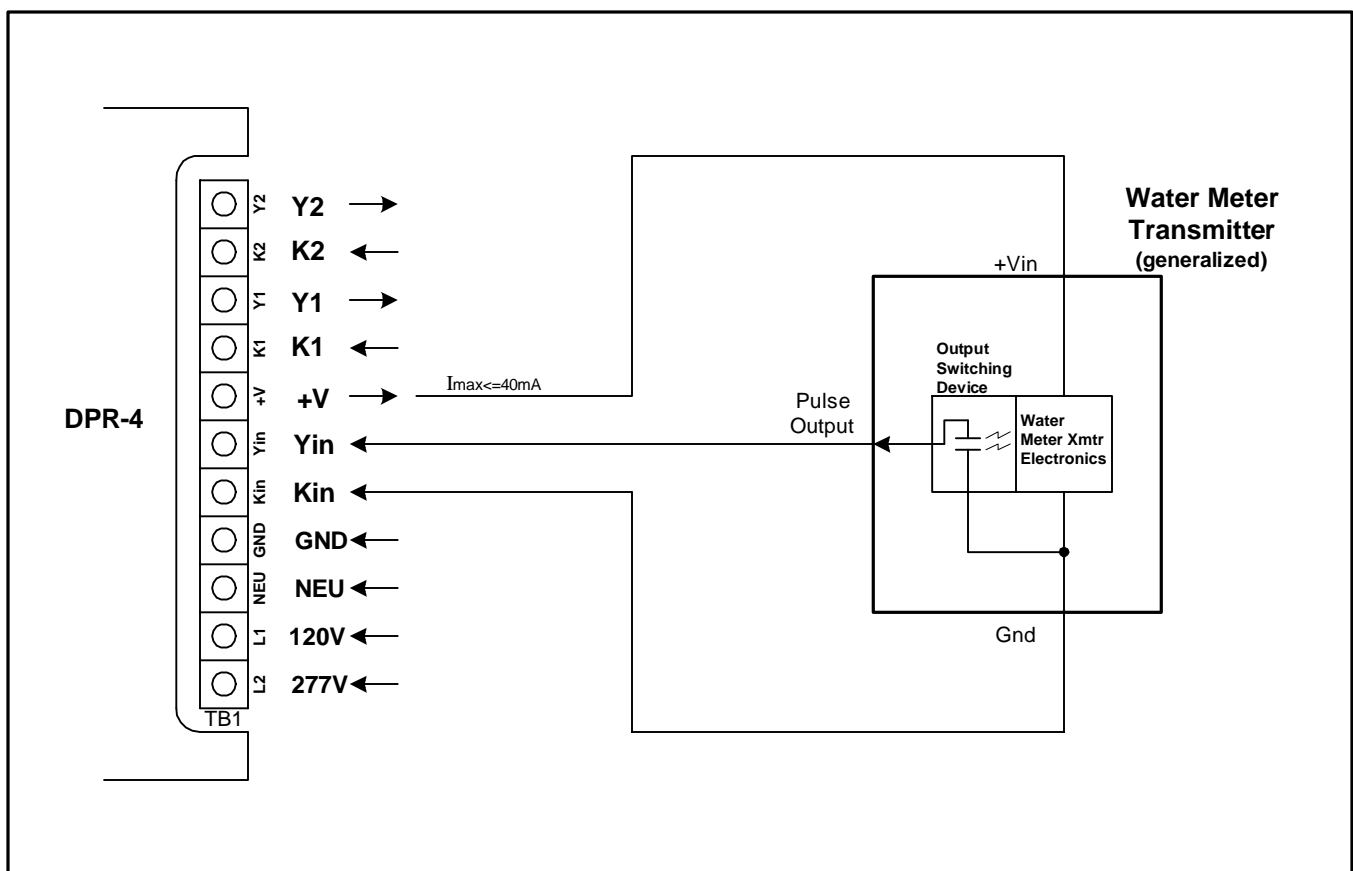

The DPR-4 supplies power via the +V pin to the water meter's power supply terminal, often marked +V, +DC input or similar. The common ground or negative of the power supply connects to the "Kin" terminal of the DPR-4. It is important to note that this is the power supply ground as well as the return for the pulse output. You will note in the drawing above that one terminal of the pulse output switching device is internally tied to the common ground terminal. This may vary from device to device but in general terms seems to be the most common configuration. The pulse output pin of the water meter connects directly to the "Yin" terminal. This usually requires a pull-up resistor between the +V input pin and the Yin terminal but the DPR-4 supplies this internally so the installer need not supply this.