

MPT-8B

PULSE TOTALIZING RELAY INSTRUCTION SHEET

S2 Standard Plus

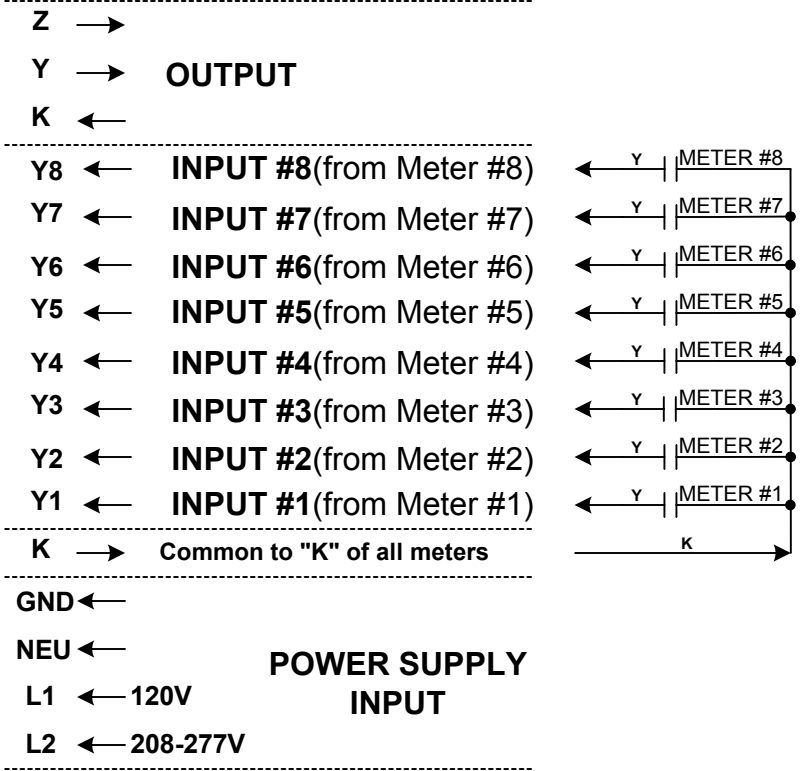
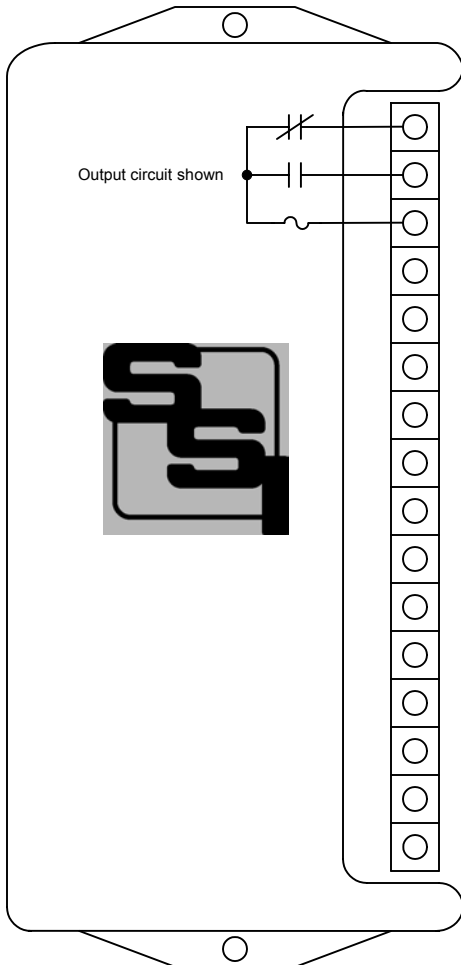

MOUNTING POSITION - The MPT-8B may be mounted in any position.

POWER INPUT - To power the MPT-8B with a 120VAC power supply, use the **NEU** and the **L1** power supply input terminals. For 208, 240 or 277 VAC operation, use the **NEU** and **L2** power supply input terminals. Connect the **GND** terminal to the electrical system ground.

METER CONNECTIONS - The MPT-8B's **K** terminal provides the common return for all of the meters' K terminals. The MPT-8B accepts only 2-Wire inputs. Connect each meter's Y terminal to the **Y** terminal of the desired input channel of the MPT-8B. Each **Y** input provides its own wetting (sense) voltage to the meter's Y terminal. Meter's pulse output can be dry-contact, solid state or mechanical.

OUTPUTS - One three-wire isolated output is provided on the MPT-8B. Arc suppression for the contacts of the solid-state relay are provided internally. The output loads should be limited to 1/4 Amp by fuse F1. A 1/4 Amp fuse is supplied standard with the unit unless otherwise specified. The fuse is a 3AG (AGC) fast blow type.



SOLID STATE INSTRUMENTS

a division of Brayden Automation Corp.
 6230 Aviation Circle, Loveland Colorado 80538
 Phone: (970)461-9600 Fax: (970)461-9605
 E-mail: support@solidstateinstruments.com

PROGRAMMING THE MPT-8B TOTALIZER

Version 2.0 Software

The MPT-8B Pulse Totalizer is programmed three small pushbutton switches (keys) located just above the LCD display. The left key with the yellow cap is the "Move Back" or previous screen key. The middle key with the orange cap is the "Move Forward" key and moves the cursor (the dash under a number on the LCD display) forward from display item to item, and if the item's digital value has changed, it enters the new value into memory. The right pushbutton switch (key) is black and is used to change the digital value in the column above the cursor. If the value above the cursor were 5, pressing the black key three times would change the display above the cursor to 8. Continued pressing of the black key would call up the value 9 and then 0, then 1...2...3...4...5...6...7...8...9...0...and so on. When the correct value to be entered is reached, press the orange key to move to the next display item. If the value at the previous display item has changed, the new value will be saved into memory. If no change is desired, just press the orange key again. All functions of the totalizer are accessible by repeatedly pressing the yellow or orange key. Upon reaching the last screen, and pressing the orange key again, the display will loop back and start again at the first display. Consequently, all the inputs can be changed and saved with a combination of pushes of the yellow, orange and black keys, as the instructions that follow will illustrate.

START-UP DISPLAY: DISPLAYS SOFTWARE VERSION

When the MPT-8B is powered up, the start-up screen will be displayed. This screen displays the Model Number on the top line and software version number of the totalizer on the bottom line. **PRESS THE ORANGE KEY TO GO TO NEXT DISPLAY.**



START-UP DISPLAY

FIRST DISPLAY: STATUS OF INPUTS/OUTPUT

If you (or the meter) connect the MPT-8B's "Y3" input terminal to the "K" (common) terminal, the third on/off box (meter #3) shown here on the status display will light. Each on/off input box shows the current status of the MPT-8B's inputs. The "Z" displayed as an output status shows that the contacts between "K" and "Z" on the output are closed or "made up". The "K" to "Y" output contact is open.

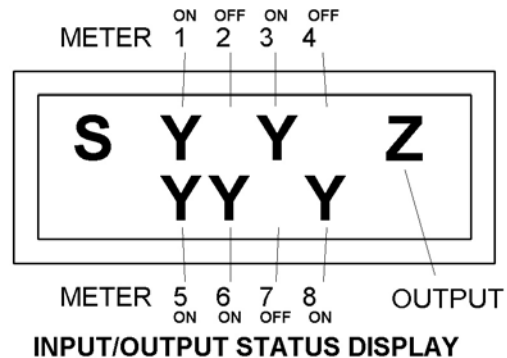

PRESS THE ORANGE KEY TO GO TO NEXT DISPLAY

SECOND DISPLAY: METER #1 KWH/PULSE VALUE

The second display is the KWH/PULSE value programmed in for METER #1. The value of each digit may be changed by first moving the cursor to the digit desired using the **ORANGE KEY**. To change the digit's value press the **BLACK KEY**. Press this key any number of times until the desired number is displayed. Press the **ORANGE KEY** once to advance the cursor to the next position to the right. Again enter the correct number with the **BLACK KEY**. Press the **ORANGE KEY** once. Enter the third number with the **BLACK KEY**. Press the **ORANGE KEY** once and enter the fourth number with the **BLACK KEY**. This time when you press the **ORANGE KEY**, you will advance to the third display.

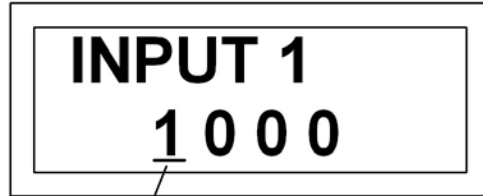

CURSOR

METER #1 KWH/P VALUE DISPLAY

THIRD DISPLAY: METER #2 KWH/PULSE VALUE

The third display works to input KWH/PULSE values for METER #2 in the same manner as display #2 worked for METER #1.

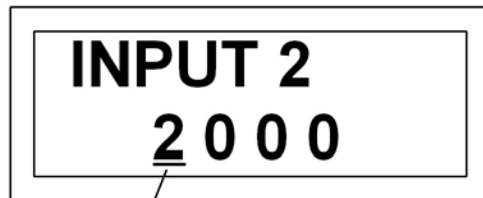

CURSOR

METER #2 KWH/P VALUE DISPLAY

FOURTH DISPLAY: METER #3 KWH/PULSE VALUE

The fourth display works to input KWH/PULSE values for METER #3 in the same manner as display #2 worked for METER #1.

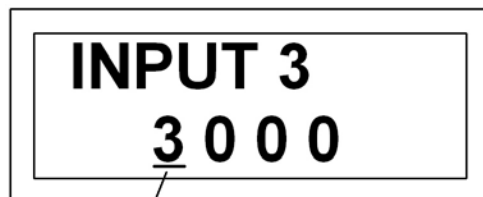

CURSOR

METER #3 KWH/P VALUE DISPLAY

FIFTH DISPLAY: METER #4 KWH/PULSE VALUE

The fifth display works to input KWH/PULSE values for METER #4 in the same manner as display #2 worked for METER #1.

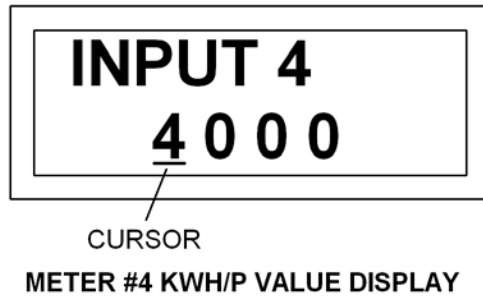

SIXTH DISPLAY: METER #5 KWH/PULSE VALUE

The sixth display works to input KWH/PULSE values for METER #5 in the same manner as display #2 worked for METER #1.

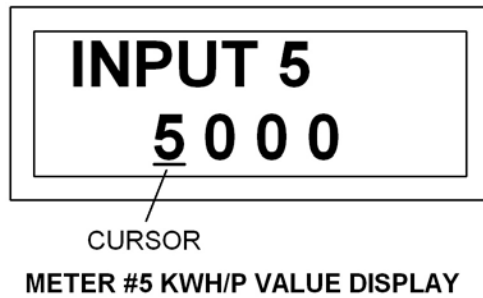

SEVENTH DISPLAY: METER #6 KWH/PULSE VALUE

The seventh display works to input KWH/PULSE values for METER #6 in the same manner as display #2 worked for METER #1.

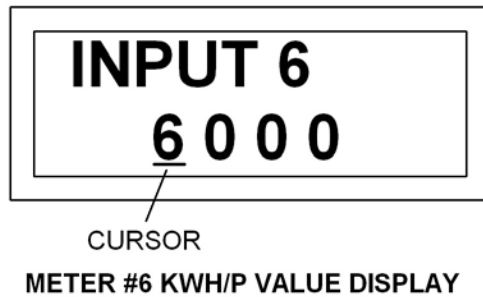

EIGHTH DISPLAY: METER #7 KWH/PULSE VALUE

The eighth display works to input KWH/PULSE values for METER #7 in the same manner as display #2 worked for METER #1.

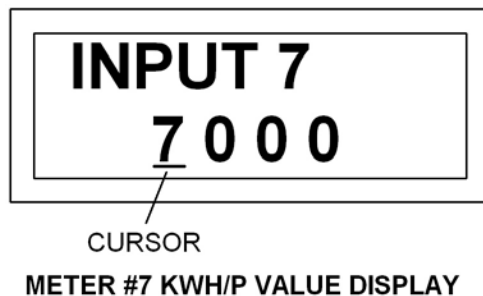

NINTH DISPLAY: METER #8 KWH/PULSE VALUE

The ninth display works to input KWH/PULSE values for METER #8 in the same manner as display #2 worked for METER #1.

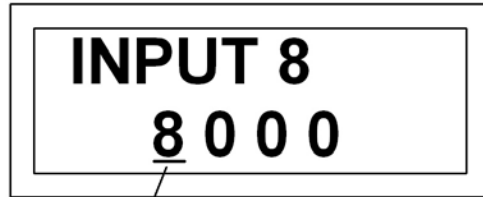

CURSOR

METER #8 KWH/P VALUE DISPLAY

TENTH DISPLAY: TOTALIZER OUTPUT KWH/PULSE VALUE

The tenth display, unlike the meter displays, has 6 digits that may be set. It is set in the same manner as the meter displays. The number entered here is the value of each output pulse. When the PV Total is equal to or exceeds the output pulse value, it is subtracted from the PV Total, and causes an output pulse (a change of state of the output relay) to occur. This value must be greater than or equal to 1 (one). If the user inadvertently puts zero (0) in this field, a one (1) will be automatically placed on the LCD in the furthest right position. The desired output value may then be entered. **PRESS THE ORANGE KEY TO GO TO NEXT DISPLAY.**

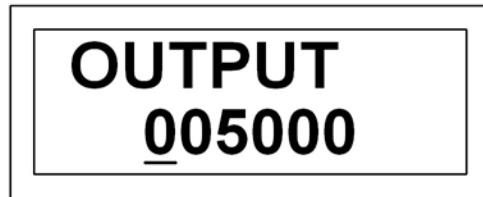

OUTPUT KWH/P VALUE DISPLAY

ELEVENTH DISPLAY: MINIMUM PULSE INPUT TIME

The eleventh display allows you to set a minimum time in milliseconds for input pulses. Because the MPT-8B accepts 2-wire ("K" & "Y") inputs, some method must be used to assure that the incoming pulses represent valid data and not noise. To accomplish this, the MPT-8B allows the user to set the minimum desired pulse duration via the MINIMAL PULSE INPUT TIME ENTRY. If the value is set to 50 milliseconds, only pulses of 50 milliseconds or more in duration followed by a zero pulse or rest space of 50 milliseconds or longer will be accepted as valid.

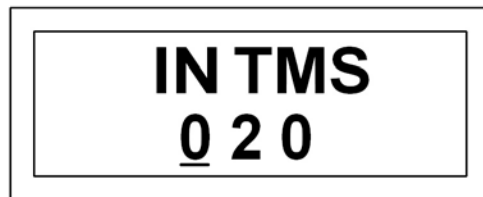

MIN. PULSE INPUT TIME DISPLAY

In the illustration to the right, the normal pulses with correct timing intervals of T1 & T2, and T8 & T9 accepted by the MPT-8B. The shorter pulse with a timing interval of T4 fails for two reasons: First, T4 is too short and secondly the interspace time T6 is also too short, however, it's recovery time, T7, is acceptable. Because most noise bursts associated with electrical

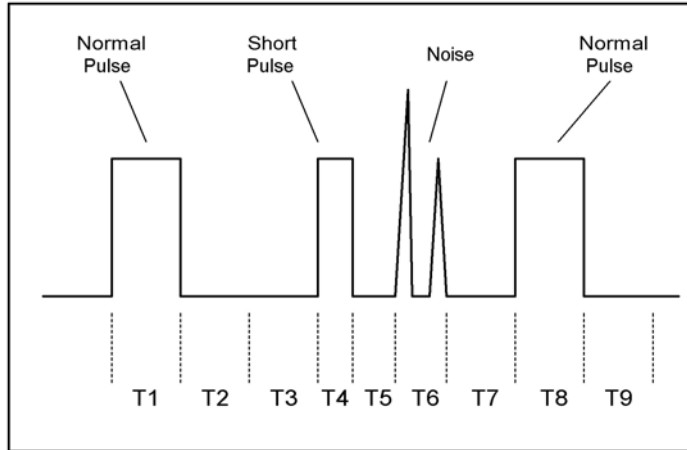

power systems are less than one cycle long, we recommend that the minimum setting be 30 milliseconds. This still allows a pulse input rate to the MPT-8B of 33 pulses per second, a rate much higher than usually experienced. The absolute minimum setting that the MPT-8B will accept is 10 milliseconds. The maximum time is 250 milliseconds. Entry is in 10 millisecond increments. The entry process is the same as that used with the meter input values.

TWELFTH DISPLAY: TIME BETWEEN OUTPUT PULSES

The twelfth display allows you to set a minimum time between output pulses to accommodate differences in required recording equipment, energy management systems and relay minimal make-up times. The minimum time is 20 milliseconds and is set in increments of 10 milliseconds. The maximum time is 1000 milliseconds (1 second). The entry procedure is the same as that used to set the meter input values.



TIME BETWEEN PULSES DISPLAY

THIRTEENTH DISPLAY: PULSE VALUE DISPLAY

The thirteenth display shows the numerical value contained within the processor's memory at any given time. For example, assume that you have set METER #1's input pulse value to 2000, all other METER inputs to 0000, an OUTPUT pulse value of 005000 and a TIME BETWEEN PULSES value of 500 mS. Upon entering three (3) pulses into METER #1's input, several things happen. First, the pulse accumulator registers



PULSE VALUE DISPLAY

a value of 6000 (3 pulses X 2000/pulse). Since the accumulator is greater than the Output Pulse Value setting, an output pulse occurs. Next, 5000 (the output value) is subtracted, leaving a display of 1000 in the PV TOTAL display. Finally, if the total in the PV had still exceeded 5000, then after 500mS, another output pulse would have occurred. The remainder will usually be smaller than the output pulse value and is only awaiting sufficient pulses at the meter inputs before a new output pulse is generated and a new smaller remainder calculated. This setting is stored in non-volatile memory upon loss of power.

FOURTEENTH DISPLAY: OUTPUT COUNT TOTAL VALUE

The fourteenth display, the OUTPUT COUNT TOTAL is a counter which records the number of output pulses since the last reset of the counter. This is simply a counter and does not take into account the value of each pulse, but increments by one count each time an output pulse occurs. This number is saved in non-volatile memory upon loss of power.



OUTPUT PULSE COUNT DISPLAY

FIFTEENTH DISPLAY: RESET COUNTERS

The fifteenth display allows you to reset the output counter and the Pulse Value Register, both at the same time. The default of this display is "N" for "no". To go back to the status display and not reset the totals, press the **ORANGE KEY**.



RESET COUNT DISPLAY

To reset all counters to zero, press and hold down the **BLACK KEY** for 3 seconds. A "Y" (for "yes") will be displayed, indicating that you are correctly pressing the key.



RESET COUNT DISPLAY

Once the MPT-8B has correctly reset the counters to zero, the display will indicate DONE. Let off the **BLACK KEY**. Upon releasing the **BLACK KEY**, the display will automatically jump back to the first display, the Status display.



RESET COUNT DISPLAY

USING THE MPT-8B WITH 3-WIRE METERING SYSTEMS

When using the MPT-8B with a 3-wire (Form C) pulse metering system, only two wires are required. All of the "K" leads from the meters are connected to the "K" terminal of the MPT-8B, the common return. A single wire is connected from the "Y" terminal of each meter to the input for each meter on the MPT-8B, i.e.: The "Y" lead (meter #1) to Y1 (MPT-8B)...The "Y" lead (meter #8) to Y8 (MPT-8B). Because the MPT-8 is a 2-Wire system, it uses the 2-Wire value for a pulse constant. The 2-Wire system's KWH/PULSE value is normally double the 3-Wire pulse value.

INFORMATION ON SCALING OF VALUES FOR DATA ENTRY

Most totalizers are ratio devices, and the MPT-8B is no different. By a "ratio device" we mean that if the number in the right most column of the value for meter #1 is the ones value for KWH/PULSE, then all other values in the right-hand most column will also represent ones. The second column to the left of the right column will represent tens values. The third column will represent the hundreds values, etc. This means that the decimal point when used can be located between any two columns or to the left or right of the first or last digit...but...the decimal point once placed in a column must run top to bottom in that position only.

EXAMPLES

CORRECT

METER #1	.1000
METER #2	.1234
METER #3	.2345
METER #4	.3456
OUTPUT	05.0000

CORRECT

METER #1	1.000
METER #2	1.234
METER #3	2.345
METER #4	3.456
OUTPUT	05.000

INCORRECT

METER #1	.1000
METER #2	1.234
METER #3	.2345
METER #4	345.6
OUTPUT	05.0000

INCORRECT

METER #1	1000.
METER #2	123.4
METER #3	23.45
METER #4	3.456
OUTPUT	00.5000

While we have used KWH/PULSE for the pulse values throughout this document, the values could be watts, megawatts, gallons or any other common unit of measure.

TECHNICAL SUPPORT

For additional information or technical help, call **Solid State Instruments**, a division Brayden Automation Corp. at (970) 461-9600.

INSTALLATION RECORD

METER NAME/NUMBER.....

METER LOCATION.....

DATE INSTALLED.....

TOTALIZER TYPE..... MPT-8B

SOFTWARE VERSION VERSION 2.0

MANUFACTURER..... SOLID STATE INSTRUMENTS

A division of Brayden Automation Corp.

6230 Aviation Circle

Loveland, CO 80538

HELP (970) 461-9600

FILL OUT BEFORE PROGRAMMING TOTALIZER

METER # 1 CIRCUIT NAME KWH/PULSE

METER # 2 CIRCUIT NAME KWH/PULSE

METER # 3 CIRCUIT NAME KWH/PULSE

METER # 4 CIRCUIT NAME KWH/PULSE

METER # 5 CIRCUIT NAME KWH/PULSE

METER # 6 CIRCUIT NAME KWH/PULSE

METER # 7 CIRCUIT NAME KWH/PULSE

METER # 8 CIRCUIT NAME KWH/PULSE

OUTPUT VALUE..... KWH/PULSE

NOTE: The MPT-8B does not actually display a decimal point. Simply decide where you want the decimal point to be and enter all numbers accordingly. When entering your values on the above record/worksheet all decimals for data entries **must** be in a vertical straight line for the math to work correctly. The decimal point may be between, before or after any column.