

# PCR-3PS

*Elite Solid State*

# UNIVERSAL PULSE CONVERSION RELAY INSTRUCTION SHEET

(True 3-Wire to 2-Wire OR 2-Wire to 3-Wire Conversion)

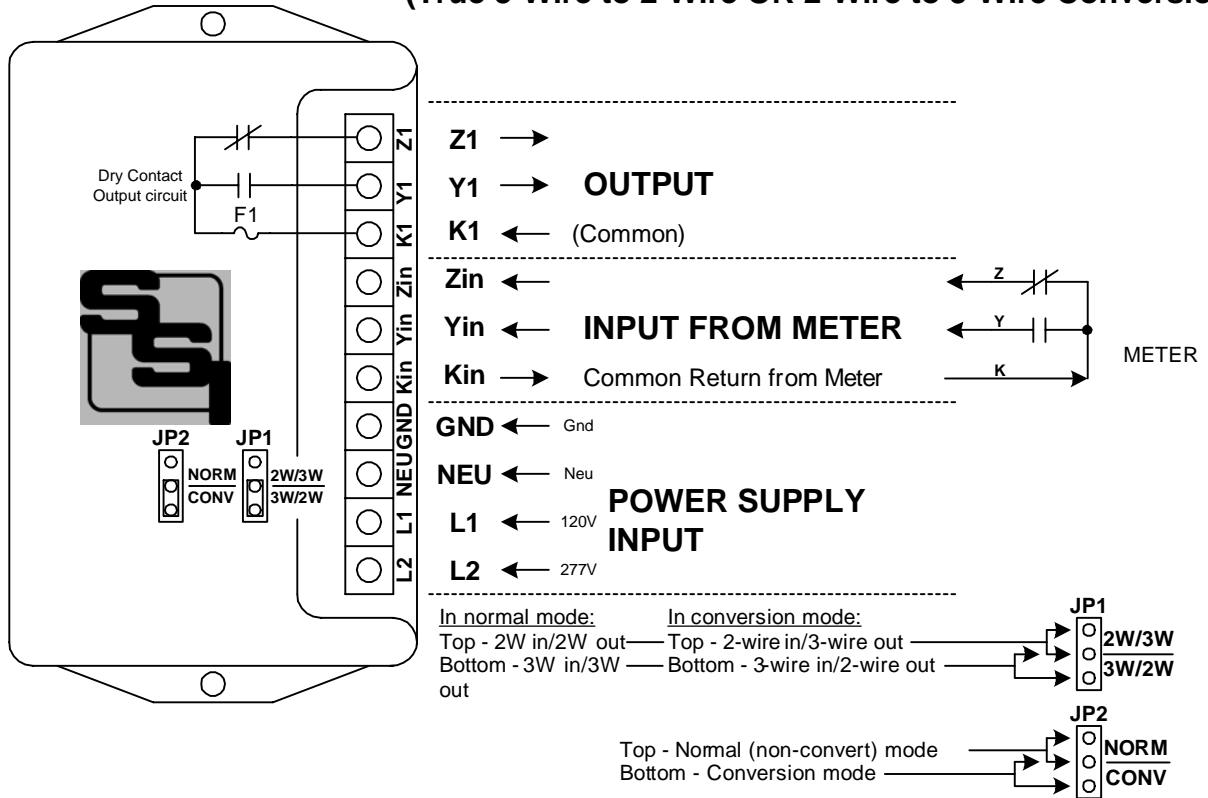

**MOUNTING POSITION** - The PCR-3PS may be mounted in any position.

**POWER INPUT** - For 120VAC line connection, connect the 120VAC HOT lead to the **L1** terminal. For 208 to 277VAC line connection, connect the 208 to 277VAC HOT lead to the **L2** terminal. Connect the **NEU** terminal to the neutral lead. Connect the **GND** terminal to the electrical system ground.

**METER CONNECTIONS** - The PCR-3PS' "Kin", "Yin" and "Zin" input terminals should be connected to the meter's "K", "Y" and "Z" output terminals for a 3-Wire connection: "Kin" to "K", "Yin" to "Y", and "Zin" to "Z". The PCR-3PS' "Kin" terminal provides the common return from the meter's "K" terminal. For a 2-Wire meter connection, connect the meter's "K" and "Y" output terminals to the PCR-3PS' "Kin" and "Yin" input terminals.

**OUTPUTS** - One 3-wire isolated "dry-contact" output is provided on the PCR-3PS with output terminals K1, Y1 and Z1. Contact rating is 1/2 Amp (500mA) up to 250VAC/VDC with a 100VA maximum power dissipation. MOV transient suppression for the solid state relay is provided internally.

**FUSES** - The fuse is a type 3AG (AGC) and may be up to 1/2th Amp in size. A 1/2 Amp fuse (F1) is supplied standard with the unit unless otherwise specified.

**OPERATION** - Set JP2 for Normal (NORM) "straight through" operation or for Conversion mode (CONV). For 2-Wire to 3-Wire conversion, set Jumper JP1 in the **top** position. For each input pulse, the output will change state, alternately giving continuity (closure) between K1 and Y1 on the first pulse, then between K1 and Z1 upon the next pulse. For 3-Wire to 2-Wire conversion, set Jumper JP1 in the **bottom** position. For each change of the input state, there will be an output pulse (contact closure) between terminals K1 and Y1 of approximately 100 milliseconds. (There will also be a corresponding contact opening of the output contacts of 100mS between K1 and Z1, if this contact type is desired.)



## SOLID STATE INSTRUMENTS

a division of Brayden Automation Corp.  
6230 Aviation Circle, Loveland Colorado 80538  
Phone: (970)461-9600 Fax: (970)461-9605  
E-mail: support@solidstateinstruments.com

# WORKING WITH THE PCR-3PS RELAY

**OPERATING MODES:** The PCR-3PS Universal Pulse Conversion Relay does 3-Wire to 2-Wire OR 2-Wire to 3-Wire pulse conversion. Below are timing diagrams which illustrate the PCR-3PS' function in each mode.

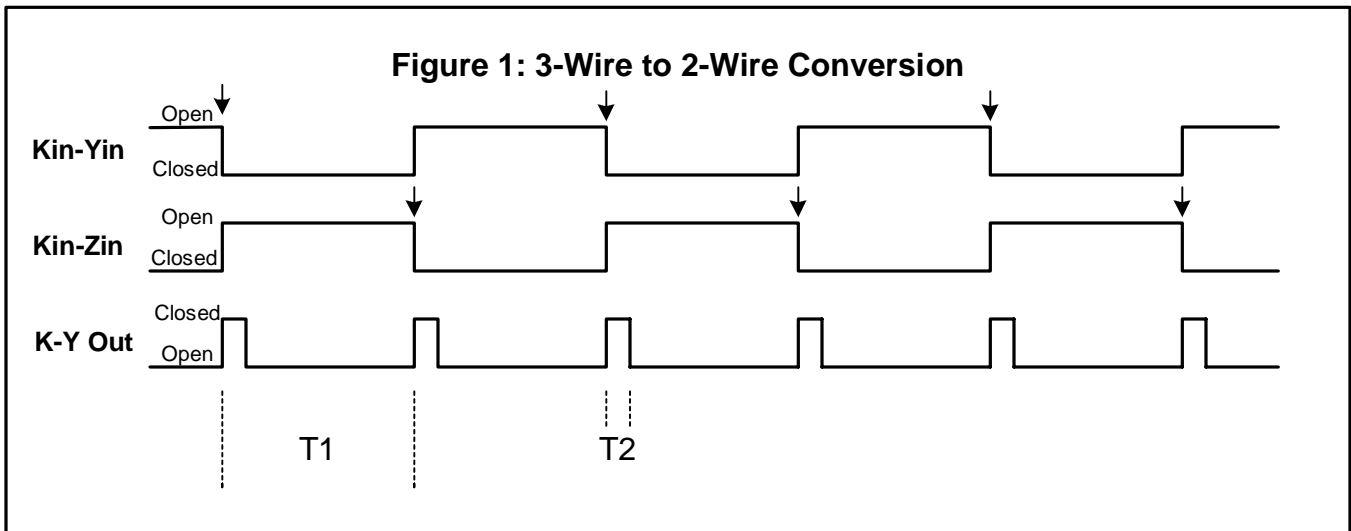

In the 3-Wire to 2-Wire conversion mode (shown above), each closure between Kin and Yin, and alternately between Kin and Zin causes the PCR-3PS to generate an output pulse (closure of the K to Y output terminals) of 100mS. An input of less than 20mS is ignored since it is most likely to be noise. An input of 20mS or longer is classified as a valid input. The input pulse duration (T1) must be greater than approximately 110mS since it must be longer than the output pulse width (T2) which is fixed at 100mS. This results in a maximum input pulse rate of 9 pulses per second.

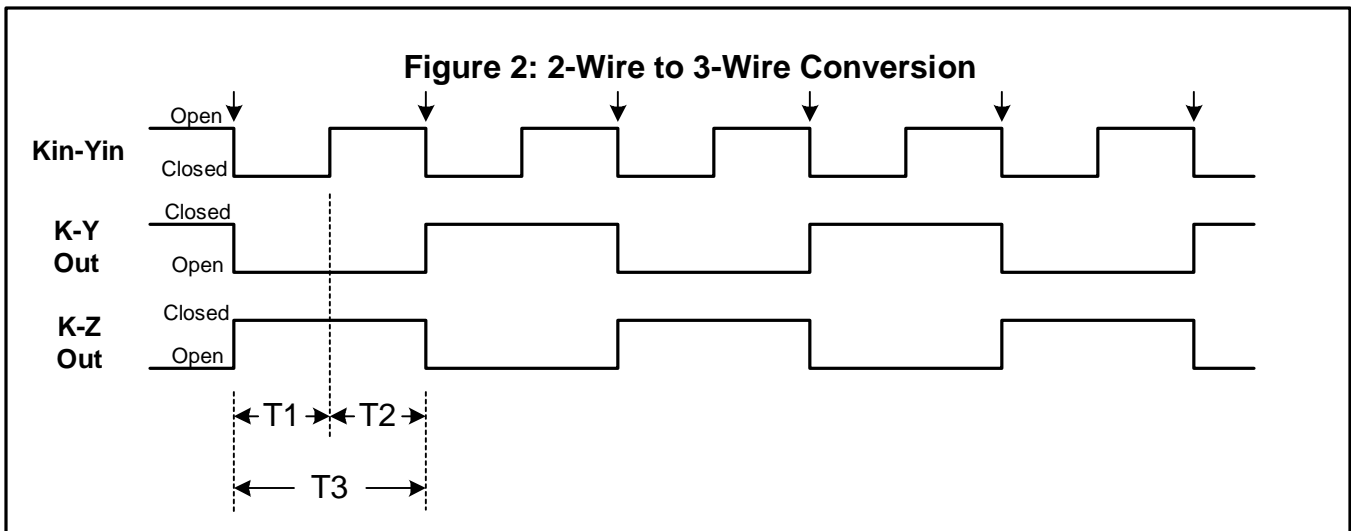

In the 2-Wire to 3-Wire conversion mode, each closure between Kin and Yin (as shown above by the arrows) causes the PCR-3 to generate an output pulse - a closure of the K to Y (and alternately K to Z) output contact terminals. The open state (T2) of the Kin and Yin terminals (absence of connection) results in no action. An active input state (T1) must be 20mS or longer to be classified as a valid input. Otherwise, the is ignored. Each output pulse's duration (T3) is equal to  $T1 + T2$ . Maximum input pulse rate in this mode is 20 pulses per second.

# WIRING THE PCR-3 RELAY

**3-Wire To 2-Wire MODE:** Wire the PCR-3PS for 3-Wire to 2-Wire pulse conversion as follows:

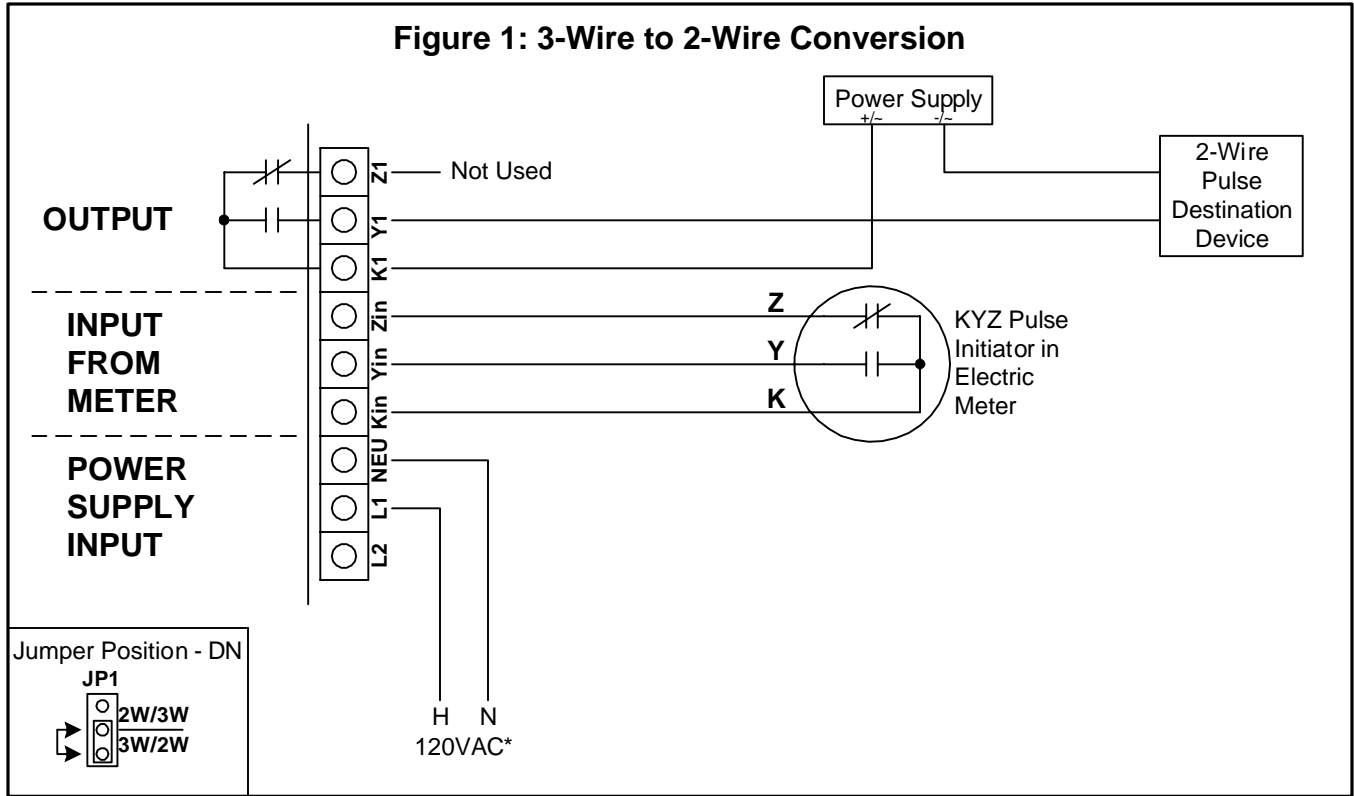

**2-Wire To 3-Wire MODE:** Wire the PCR-3PS for 2-Wire to 3-Wire pulse conversion as follows:

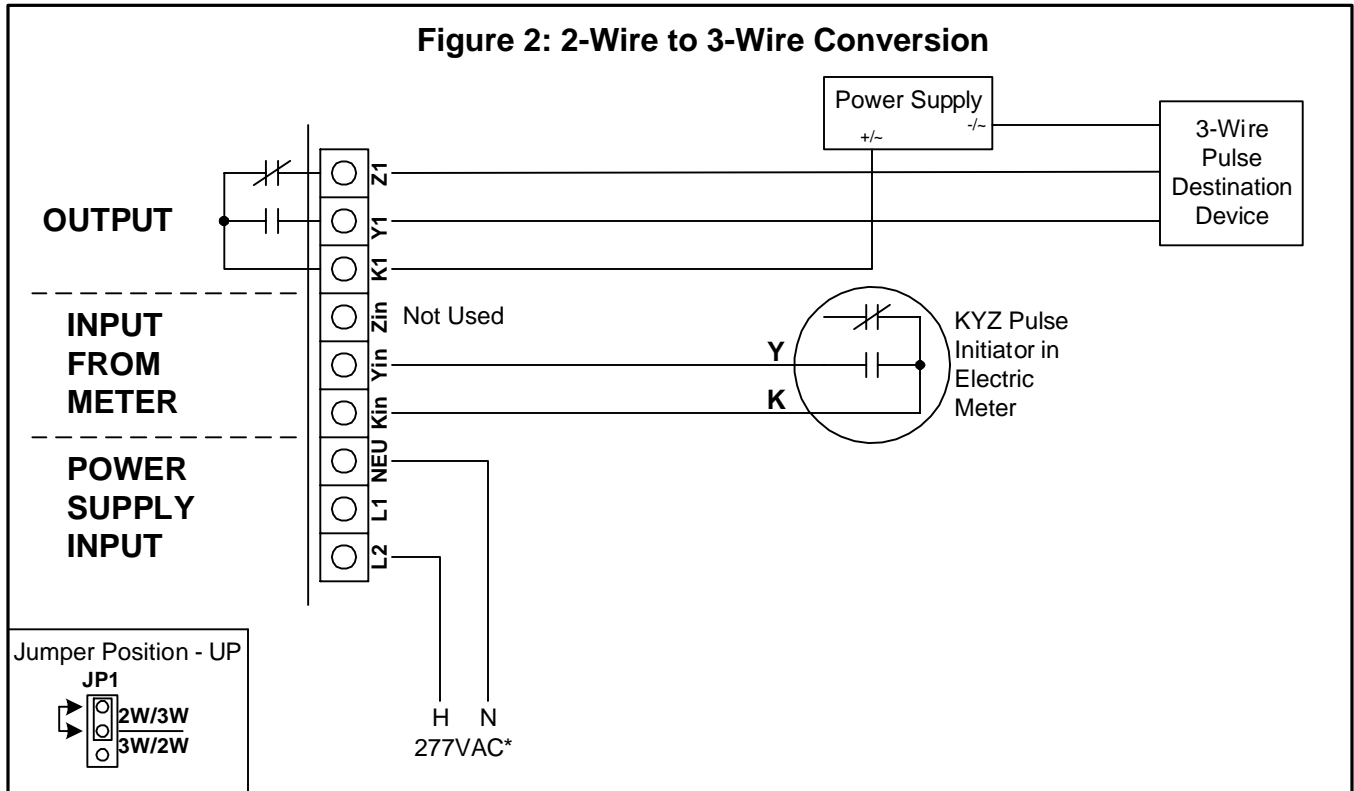

\* Shown as example only