

RTR-2+

Standard Solid State

HIGH SPEED PULSE ISOLATION RELAY INSTRUCTION SHEET

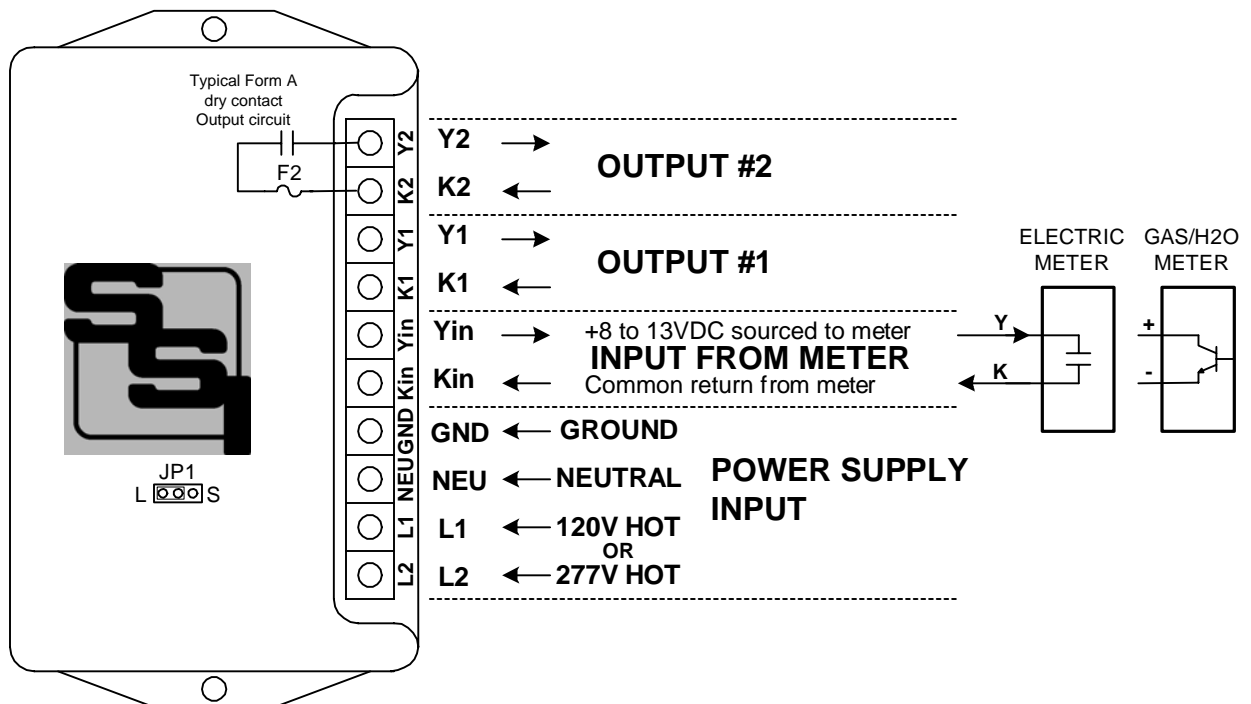

MOUNTING POSITION - The RTR-2+ may be mounted in any position.

POWER INPUT - For a 120VAC power supply, connect the "hot" lead to the **L1** terminal. For a 208 to 277VAC power supply, connect the "hot" lead to the **L2** terminal. Connect the Neutral power supply lead to the **NEU** terminal. Connect the electrical system ground to the **GND** terminal. Do not use both L1 and L2. The unit must be grounded for proper operation.

METER CONNECTIONS - The RTR-2+'s **Kin** and **Yin** input terminals are connected to the meter's input terminals. The RTR-2+'s **Yin** terminal provides a "pulled up" +13VDC wetting voltage. The **Kin** terminal is the common return. When the output contact closes, the "Yin" input line is switched. As long as the pulse output is a non-polarized dry contact type, it does not matter which input terminal is connected to each output terminal of the pulse initiating device. If however, the output device is an open-collector transistor, then the collector (or the "+") must be connected to the Yin terminal. The emitter (or negative - terminal) must go to Kin.

FUSES - The fuses are type 3AG and may be up to 1/10 Amp in size. A 1/10 Amp fuse is supplied standard with the unit unless otherwise specified.

OUTPUTS - Under the RTR-2+'s cover in the center of the board just above the power transformer is a 3-pin header labeled **JP1**. This selects either the **Long** (LEFT) or the **Short** (RIGHT) output pulse mode. Use the long (L) mode to have the output pulse length match the input pulse length. See page 3 of this sheet for additional information on selecting system settings. Arc suppression for the contacts of the solid state relay is provided internally.



SOLID STATE INSTRUMENTS

a division of Brayden Automation Corp.
6230 Aviation Circle, Loveland Colorado 80538
Phone: (970)461-9600 Fax: (970)461-9605
E-mail: support@solidstateinstruments.com

WORKING WITH THE RTR-2+ RELAY

BLOCKING NOISE: The RTR-2+ has a built-in noise rejection software algorithm for detecting valid pulses from a sending source. The algorithm accomplishes this by measuring the time the input pulse is present. If the input pulse is present for less than the specified time (in milliseconds) as determined by the position of jumpers **JP4** and **JP5**, it is assumed to be noise. An input equal or longer in duration than the specified time is classified as a valid input and an output will occur. In the illustration to the left,

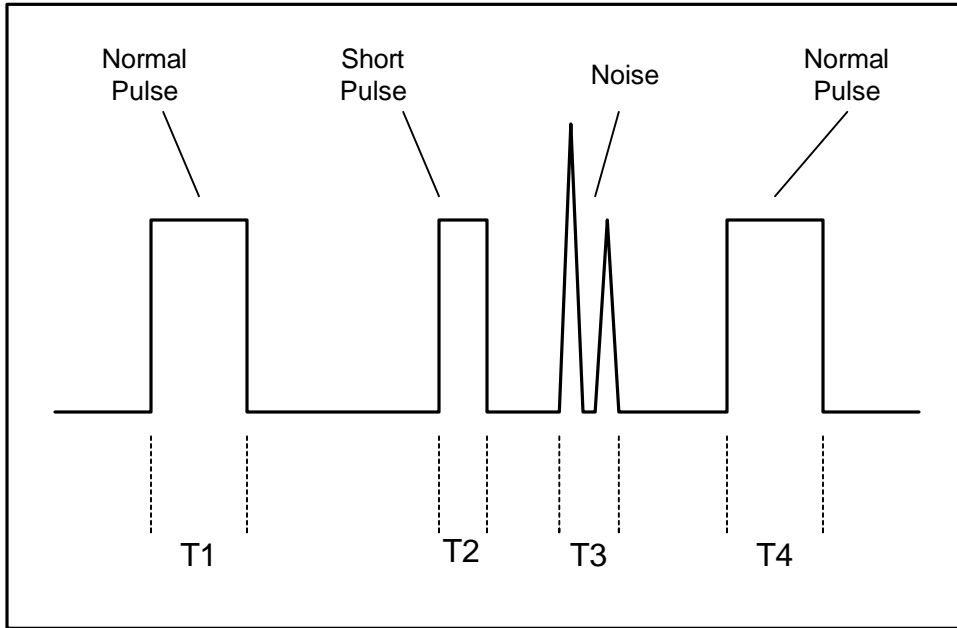

the normal pulses with time durations of T1 and T4 will cause an output. The short pulse of time duration T2 and the noise with duration T3 will be rejected because the length of time (pulse width) is too short, even though the voltage is of sufficient magnitude. The time T4 could be many times as long as T1 and it would still be a valid time pulse since it has met the minimum time requirement. The time duration of 20 milliseconds (max) has been chosen as the factory-set default value since one cycle of the 60 hertz AC line frequency represents 16.67 milliseconds. Most induced noise and arcing discharges do not last longer than this, while most contact closures are a great deal longer. The time duration of the may be modified by changing jumpers JP4 and JP5. See table 1 on Page 3 for input filtering times.

OUTPUT PULSE DURATION: The RTR-2+ can output two types of pulses - long or short - depending upon the position of the small 3-pin header **JP1** located in the middle of the board just above the transformer and to the left of the Yin terminal. In the "S" (right) position, the RTR-2+ outputs a "short" pulse which has a duration determined by the position of jumpers **JP2** and **JP3**. Once a valid pulse has been qualified, the output pulse will be set and time specified output time will begin timing out. See Table 2 on page 3 for the selectable output pulse lengths. If the switch is in the "S" position and the incoming pulse is of sufficient time duration to be a valid pulse, but is less than 100 milliseconds, for example, the output time period will still be 100 milliseconds. Thus, the RTR-2+ can be used as a pulse stretcher. In the "L" (left) position, the RTR-2+ outputs a "long" pulse which is the same duration as the valid input pulse plus the specified input time. Thus, the maximum pulse rate is dependent on the positions of jumpers JP2 through JP5. If no jumpers are installed, the RTR-2+ will default to the long output mode, 20mS input time, and output will mirror the input pulse length.

CONFIGURING THE RTR-2+ RELAY

INPUT DEBOUNCE TIMES - The RTR-2+ contains four different input debouncing time options. A pulse received at the RTR-2+'s input must be present for at least the specified amount of time to be considered a valid pulse. Minimum pulse times can be set in the following times: 50uS, .5mS, 5mS or 20mS. For most electric meter pulse applications, the 20mS input time will be satisfactory. For high speed pulse applications with water or gas meters, the minimum input time may need to be reduced depending on the meter's output pulse width. The table below shows how to set jumpers **JP4** and **JP5** for the selected time.

Table 1

JP5	JP4	mS
Out	Out	20
Out	In	5
In	Out	.5
In	In	50uS

SHORT MODE OUTPUT PERIOD - When **JP1** is selecting the short output pulse mode, the duration of the output time can be selected by using jumpers **JP2** and **JP3**. Output times are selectable as follows: 50mS, 100mS, 200mS and 500mS. The receiving equipment may require pulses to be of a given minimum length to be considered a valid pulse. If input pulses are received while a short output pulse is timing out, the RTR-2+ will store the received pulse(s) and output them as soon as the current pulse has timed out. The time between pulses is the same as the specified pulse time, giving a maximum of a 50/50 duty cycle. A maximum of 255 output pulses can be stored.

Table 2

JP3	JP2	mS
Out	Out	50
Out	In	100
In	Out	200
In	In	500

RTR-2+ Wiring Diagram Electric Meter Application

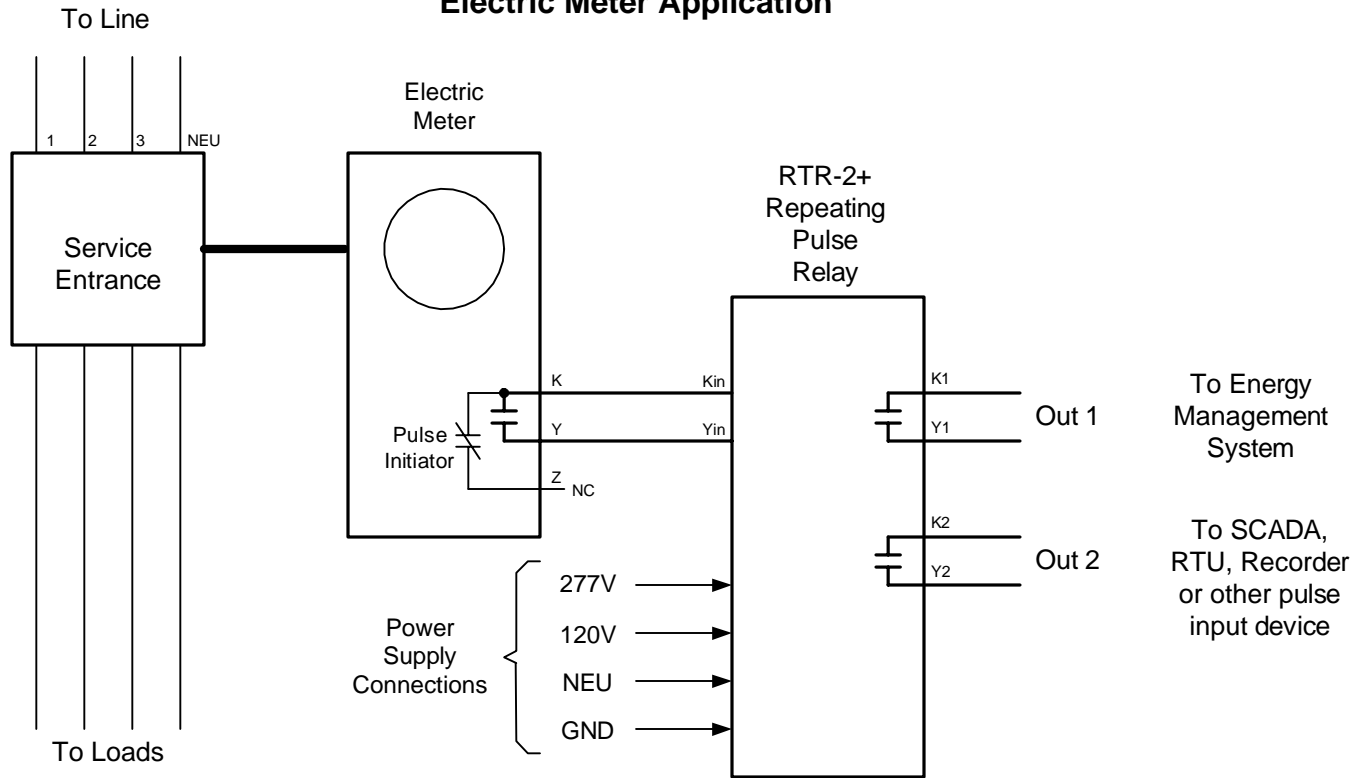

Water or Gas Meter Application

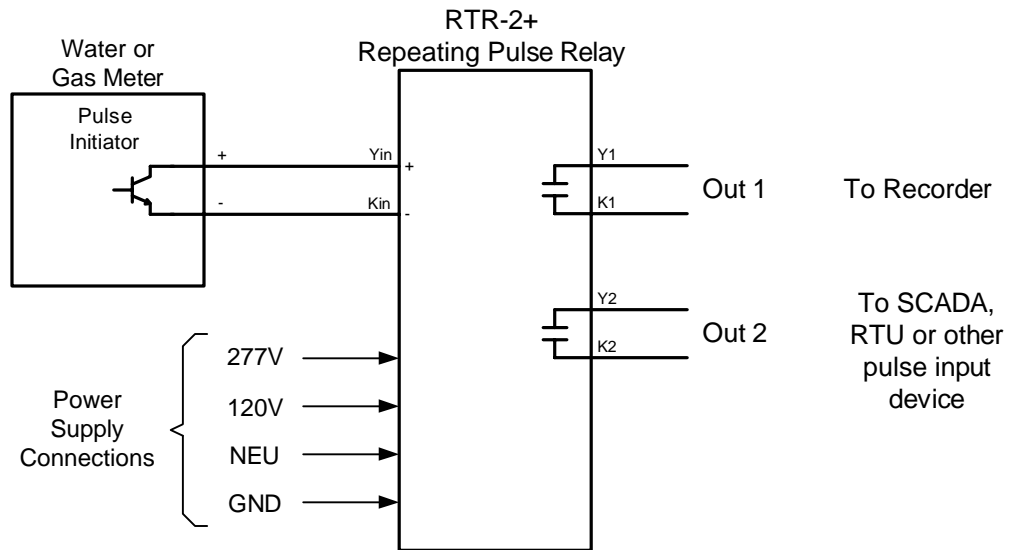

RTR-2+ Repeating Pulse Relay Wiring Diagram

REVISIONS

NO.	DATE	DESCRIPTION

DATE ORIGINAL: 11/01/09
SCALE: N/A

LATEST REVISION: JOB NO.: CHECKED: DRAWN: WHB

**Brayden Automation Corp./
Solid State Instruments div.**
6230 Aviation Circle
Loveland, CO 80538
(970)461-9600
(970)461-9205 fax
www.solidstateinstruments.com