

SOLAR POWER SUPPLY INSTRUCTION SHEET

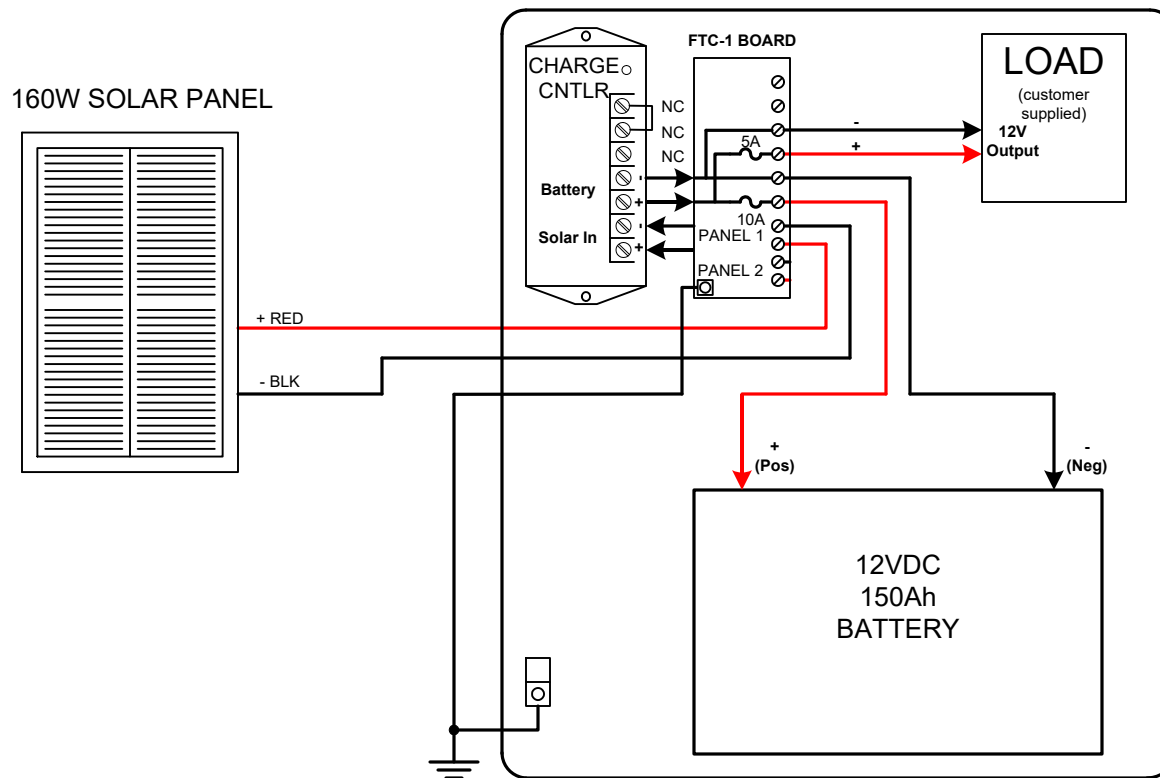

MOUNTING POSITION - The SPS-9 Enclosure must be mounted in an upright position so that the battery is placed on the bottom of the enclosure. Mount the solar panel using the metal mounting system provided to get the correct mounting angle pursuant to the instructions included in the mounting bracket kit. The solar panel mounting bracket is designed to attach to a pole or building. The Solar Panel may not be shaded by trees or a building at any time to get the maximum solar day.

POWER INPUT - Connect the Solar Panel's positive lead to the "+" input for Panel 1 on the FTC-1 termination board. Connect the solar panels' negative lead to the "-" input for Panel 1 on the FTC-1 termination board. Connect the electrical system ground to the grounding bracket on the mounting panel. **GROUND MUST BE CONNECTED**, either to the electrical system ground or a ground rod.

LOAD CONNECTIONS - The **LOAD** terminals supply +12VDC to a Load. Connect the 12V "+" Load terminal to the load's positive "+" lead. Connect the 12V "-" Load Terminal to the load's negative "-" lead.

POWER UP - Connect the marked RED lead with the RING terminal to the Battery's positive **BATT(+)** terminal.

FUSES - 10 Amp AGC or 3AG fuses are provided on the termination board for the battery's positive (+) terminal and the load terminal. 5 Amp fuses are provided for the solar panels. Fuse sizes may be reduced to a lower amperage if desired.

NORMAL OPERATION - Under normal circumstances the solar panel will output between 10 and 22 volts to the charge controller. The length of time that the battery will hold up the load is directly related to the discharge rate. The lower the discharge rate the longer the battery's charge will last. The hold-up time without any recharge from the solar panel for a 500mA load is approximately 12 days. Limit the load current to the lowest possible level for the best results.



SOLID STATE INSTRUMENTS

a division of Brayden Automation Corp.
6230 Aviation Circle, Loveland, Colorado 80538

Phone: (970)461-9600

E-mail: support@brayden.com