

MPT-4B

PULSE TOTALIZING RELAY INSTRUCTION SHEET

S2 Standard Plus

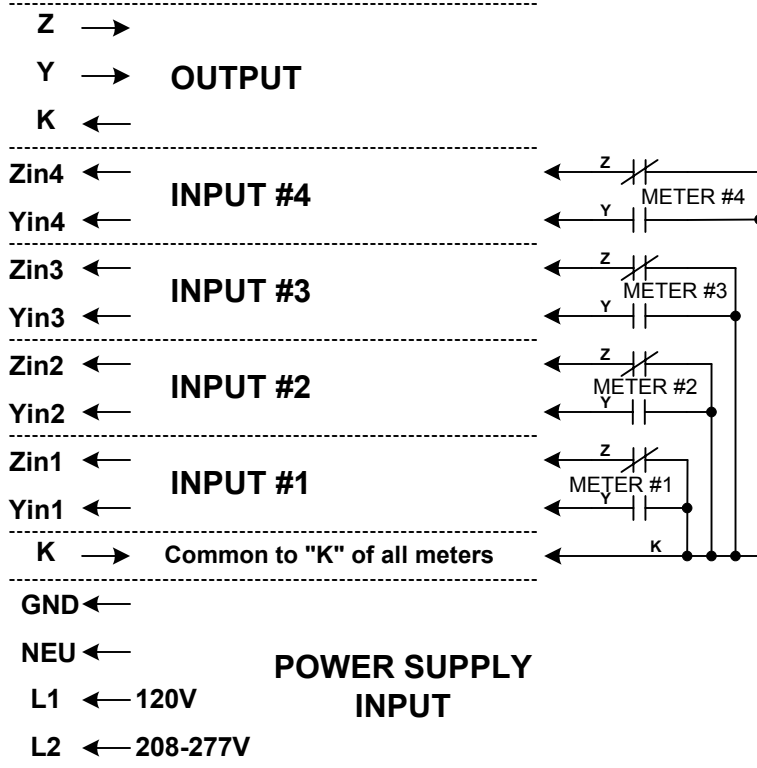
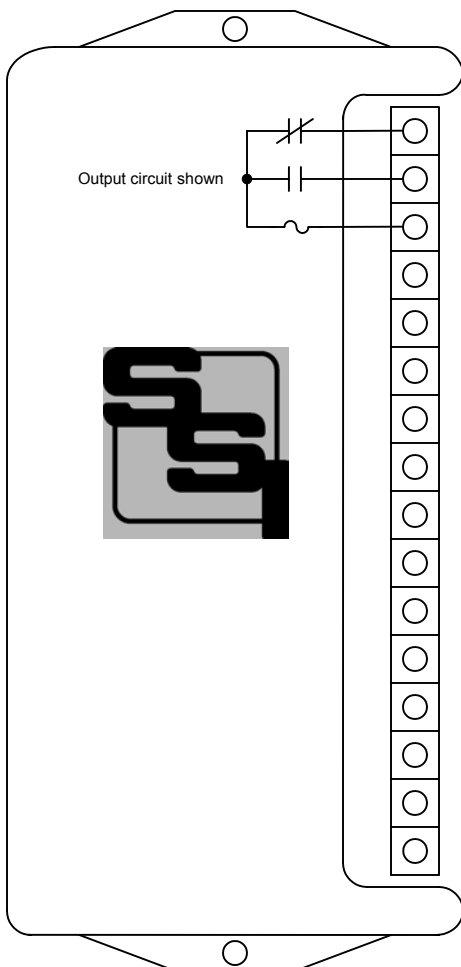

MOUNTING POSITION - The MPT-4B may be mounted in any position.

POWER INPUT - To power the MPT-4B with a 120VAC power supply, use the **NEU** and the **L1** power supply input terminals. For 208, 240 or 277 VAC operation, use the **NEU** and **L2** power supply input terminals. Connect the **GND** terminal to the electrical system ground.

METER CONNECTIONS - The MPT-4B's **K** terminal provides the common return for all of the meters' **K** terminals. The MPT-4B utilizes only 3-Wire inputs. Connect each meter's **Y** and **Z** terminals to the **Y** and **Z** terminals of the desired input channel of the MPT-4B. Each **Y** and **Z** input provide its own wetting (sense) voltage to the meter's **Y** and **Z** terminals. Meter's pulse output can be dry-contact, solid state or mechanical.

OUTPUTS - One three-wire isolated output is provided on the MPT-4B. Arc suppression for the contacts of the solid-state relay are provided internally. The output loads should be limited to 1/4 Amp by fuse F1. A 1/4 Amp fuse is supplied standard with the unit unless otherwise specified. The fuse is a 3AG (AGC) fast blow type.



SOLID STATE INSTRUMENTS

a division of Brayden Automation Corp.
6230 Aviation Circle, Loveland Colorado 80538
Phone: (970)461-9600 Fax: (970)461-9605
E-mail: support@solidstateinstruments.com

PROGRAMMING THE MPT-4B TOTALIZER

Version 2.0 Software

The MPT-4B Pulse Totalizer is programmed by using the three small pushbutton switches (keys) located just above the LCD display. The left key with the yellow cap is the "Move Back" or previous screen key. The middle key with the orange cap is the "Move Forward" key and moves the cursor (the dash under a number on the LCD display) forward from display item to item. The right pushbutton switch (key) with the black cap is used to change the value in the column above the cursor. If the value above the cursor were 5, pressing the black key three times would change the display above the cursor to 8. Continued pressing of the black key would advance the number to the value 9 and then 0, then 1...2...3...4...5...6...7...8...9...0...and so on. When the desired value is reached, press the orange key to move to the next display item. If the value at the present display position has been changed, the new value will be saved into memory as soon as you move the cursor to the next position. If no change is desired, just press the orange key again. Pressing the yellow key will move you to the previous screen. All functions of the totalizer are accessible by repeatedly pressing the yellow or orange key. Upon reaching the last screen, and pressing the orange key again, the display will loop back and start again at the first display. Consequently, all the inputs can be changed and saved with a combination of pushes of the yellow, orange and black keys, as the instructions that follow will illustrate.

START-UP DISPLAY: DISPLAYS SOFTWARE VERSION

When the MPT-4B is powered up, the start up screen will be displayed. This screen displays the Model Number on the top line and software version number of the totalizer on the bottom line. **THE DISPLAY WILL AUTOMATICALLY GO TO THE FIRST DISPLAY SCREEN AFTER 5 SECONDS.**



START-UP DISPLAY

FIRST DISPLAY: STATUS OF INPUTS/OUTPUT

If you (or the meter) cause the "Z2" input terminal to be connected to the MPT-4B's "K" common terminal, meter #2's status shown here on the display will change to a "Z". Each input shows the last transmitted status to the MPT-4B. Any input which is not used will have a "-" displayed in its position.

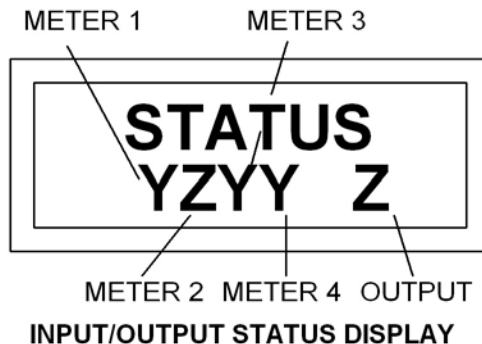

The “Z” displayed as an output status shows that the contacts between “K” and “Z” on the output are closed or “made up”. The “K” to “Y” output contacts are open. **PRESS THE ORANGE KEY TO GO TO NEXT DISPLAY.**

SECOND DISPLAY: METER #1 KWH/PULSE VALUE

The second display is the KWH/PULSE value programmed in for METER #1. The value of each digit may be changed by first moving the cursor to the digit desired using the **ORANGE KEY**. To change the digit's value press the **BLACK KEY**. Press this key any number of times until the desired number is displayed. Press the **ORANGE KEY** once to advance the cursor to the next position to the right. Again enter the correct number with the **BLACK KEY**. Press the **ORANGE KEY** once. Enter the third number with the **BLACK KEY**. Press the **ORANGE KEY** once and enter the fourth number with the **BLACK KEY**. This time when you press the **ORANGE KEY**, you will advance to the third display.

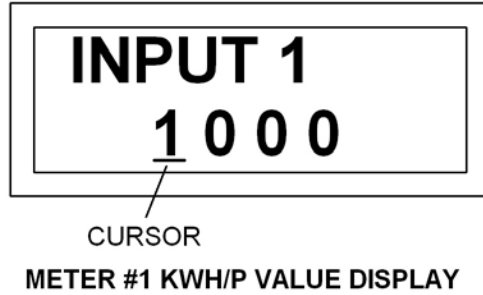

THIRD DISPLAY: METER #2 KWH/PULSE VALUE

The third display works to input KWH/PULSE values for METER #2 in the same manner as display #2 worked for METER #1.

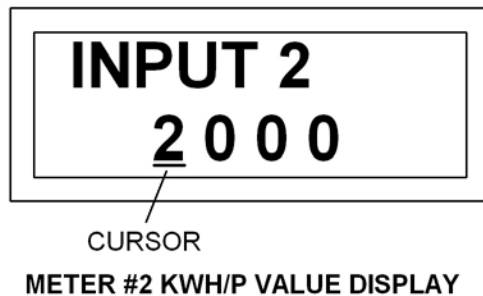

FOURTH DISPLAY: METER #3 KWH/PULSE VALUE

The fourth display works to input KWH/PULSE values for METER #3 in the same manner as display #2 worked for METER #1.

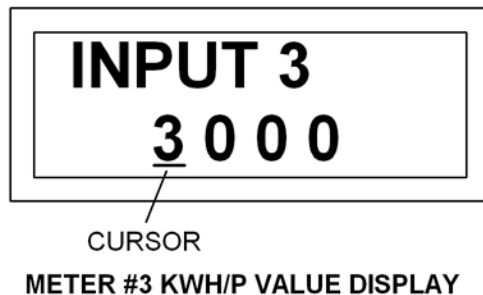

FIFTH DISPLAY: METER #4 KWH/PULSE VALUE

The fifth display works to input KWH/PULSE values for METER #4 in the same manner as display #2 worked for METER #1.

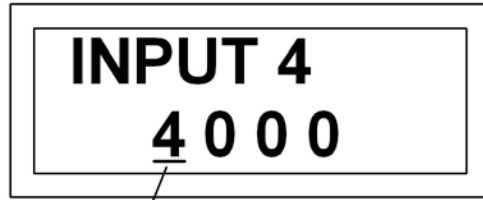

CURSOR

METER #4 KWH/P VALUE DISPLAY

SIXTH DISPLAY: TOTALIZER OUTPUT KWH/PULSE VALUE

The sixth display, unlike the preceding meter input value displays, has 6 digits that may be set. The value of the output is set in the same manner as the meter input displays. When the PV Total equals or exceeds this value, the output pulse value is subtracted from the PV Total, and causes an output pulse (a change of state of the output relay) to occur. This value must be greater than or equal to 1 (one). If the user inadvertently puts zero (0) in this field, a one (1) will be automatically placed on the LCD in the furthest right position. The desired output value may then be entered.

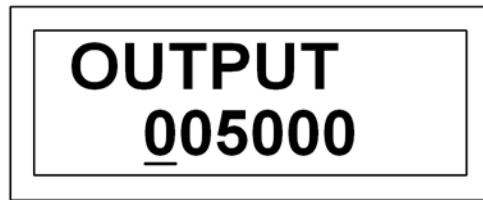

OUTPUT KWH/P VALUE DISPLAY

SEVENTH DISPLAY: TIME BETWEEN OUTPUT PULSES

The seventh display allows you to set a minimum time between output pulses to accommodate differences in required recording equipment and relay minimal make-up times. The time is set in 10-millisecond increments. The minimum time is 20 milliseconds. The maximum time is 1000 milliseconds (1 second). The entry method is the same as that used to set the meter input values.



TIME BETWEEN PULSES DISPLAY

EIGHTH DISPLAY: PULSE VALUE DISPLAY

The eighth display shows the accumulated numerical value contained within the processor's memory at any given time. For example, assume that you have set METER



PULSE VALUE DISPLAY

#1's input pulse value to 2000, all other METER inputs to 0000, an OUTPUT pulse value of 005000 and a TIME BETWEEN PULSES value of 500 mS. Upon entering three (3) pulses into METER #1's inputs, several things happen. First, the pulse accumulator registers a value of 6000 (3 pulses X 2000/pulse). Since the accumulator is greater than the Output Pulse Value setting (5000), an output pulse occurs. Next, 5000 (the output value) is subtracted, leaving a display of 1000 in the PV TOTAL display. Finally, if the total in the PV had still exceeded 5000, then after 500mS, another output pulse would have occurred. The remainder will usually be smaller than the output pulse value and is only awaiting sufficient pulses at the meter inputs before a new output pulse is generated and a new smaller remainder calculated. This setting is stored in non-volatile memory upon loss of power.

NINTH DISPLAY: INPUT PULSE COUNT – METER #1

The ninth display allows you to see the total number of pulses that have been counted by meter input #1 since the last reset. This number is simply a counter that increments by one (1) count each time a pulse is recorded by meter input #1. This value is non-weighted and represents the number of counts only. This count is saved in non-volatile memory upon loss of power. Press the **ORANGE KEY** to advance to the next display.

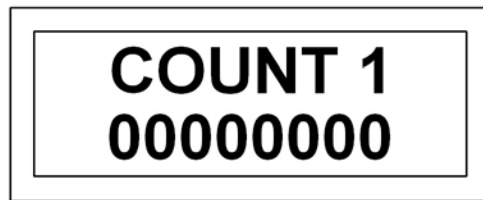

METER #1 PULSE COUNT DISPLAY

TENTH DISPLAY: INPUT PULSE COUNT – METER #2

The tenth display allows you to see the total number of pulses that have been counted by meter input #2 since the last reset. This number is simply a counter that increments by one (1) count each time a pulse is recorded by meter input #2. This value is non-weighted and represents the number of counts only. This count is saved in non-volatile memory upon loss of power. Press the **ORANGE KEY** to advance to the next display.



METER #2 PULSE COUNT DISPLAY

ELEVENTH DISPLAY: INPUT PULSE COUNT – METER #3

The eleventh display allows you to see the total number of pulses that have been counted by meter input #3 since the last reset. This number is simply a counter that increments by one (1) count each time a pulse is recorded by meter input #3. This value is non-weighted and represents the number of counts only. This count is saved in non-volatile memory upon loss of power. Press the **ORANGE KEY** to advance to the next display.



METER #3 PULSE COUNT DISPLAY

TWELFTH DISPLAY: INPUT PULSE COUNT – METER #4

The twelfth display allows you to see the total number of pulses that have been counted by meter input #4 since the last reset. This number is simply a counter that increments by one (1) count each time a pulse is recorded by meter input #4. This value is non-weighted and represents the number of counts only. This count is saved in non-volatile memory upon loss of power. Press the **ORANGE KEY** to advance to the next display.

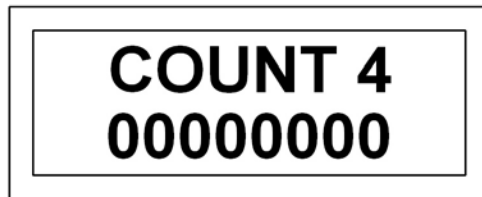

METER #4 PULSE COUNT DISPLAY

THIRTEENTH DISPLAY: OUTPUT PULSE COUNT

The thirteenth display allows you to see the total number of output pulses that have been outputted since the last reset. This number is a counter that increments by one (1) count each time a pulse is sent to the output relay. This value is non-weighted and represents the number of counts only. This count is saved in non-volatile memory upon loss of power. Press the **ORANGE KEY** to advance to the next display.

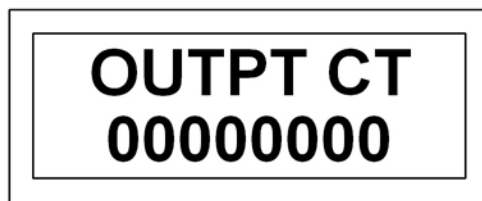

OUTPUT PULSE COUNT DISPLAY

FOURTEENTH DISPLAY: RESET COUNTERS

The fourteenth display allows you to reset the four INPUT counters, the OUTPUT counter, and the PV TOTAL register, all at one time. The default of this display is "N" for no. To go back to the status display and



RESET COUNT DISPLAY

not reset the totals, press the **ORANGE KEY**.

To reset all counters to zero, press and hold down the **BLACK KEY** for 3 seconds. A “Y” will be displayed, indicating that you are correctly pressing the key.



RESET COUNT DISPLAY

Once the MPT-4B has correctly reset all counters to zero, the display will indicate DONE. Let off the **BLACK KEY**. Upon releasing the **BLACK KEY**, the display will automatically jump back to the first display, the Status display.



RESET COUNT DISPLAY

INFORMATION ON SCALING OF VALUES FOR DATA ENTRY

Most totalizers are ratio devices, and the MPT-4B is no different. By a “ratio device” we mean that if the number in the right-most column of the value for meter #1 is the “ones” value for KWH/PULSE, then all other values in the right-hand most column will also represent “ones”. The second column to the left of the right column will represent “tens” values. The third column will represent the “hundreds” values, etc. This means that the decimal point, when used, can be located between any two columns or to the left or right of the first or last digit. However, once the decimal point is placed in a column, it must run top to bottom in that position only.

EXAMPLES

CORRECT

METER #1	.1000
METER #2	.1234
METER #3	.2345
METER #4	.3456
OUTPUT	05.0000

CORRECT

METER #1	1.000
METER #2	1.234
METER #3	2.345
METER #4	3.456
OUTPUT	05.000

INCORRECT

METER #1 .1000
METER #2 1.234
METER #3 .2345
METER #4 345.6
OUTPUT 05.0000

INCORRECT

METER #1 1000.
METER #2 123.4
METER #3 23.45
METER #4 3.456
OUTPUT 00.5000

While we have used KWH/PULSE for the pulse values throughout this document, the values could be watts, megawatts, gallons or any other common unit of measure.

TECHNICAL SUPPORT

For additional information or technical help, call Brayden Automation Corp./Solid State Instruments division at (970) 461-9600 or toll free at (888)BRAYDEN.

INSTALLATION RECORD

METER

NAME/NUMBER.....

METER LOCATION.....

DATE INSTALLED.....

TOTALIZER TYPE..... MPT-4B

SOFTWARE VERSION VERSION 2.0

MANUFACTURER..... SOLID STATE INSTRUMENTS

A division of Brayden Automation Corp.

6230 Aviation Circle

Loveland, CO 80538

HELP (970) 461-9600

FILL OUT BEFORE PROGRAMMING TOTALIZER

METER # 1 CIRCUIT NAME KWH/PULSE

METER # 2 CIRCUIT NAME KWH/PULSE

METER # 3 CIRCUIT NAME KWH/PULSE

METER # 4 CIRCUIT NAME KWH/PULSE

OUTPUT VALUE KWH/PULSE

NOTE: The MPT-4B does not actually display a decimal point. Simply decide where you want the decimal point to be and enter all numbers accordingly. When entering your values on the above record/worksheet, all decimals for data entries **must** be in a vertical straight line for the math to work correctly. The decimal point may be between, before or after any column.